

### OVERVIEW

Walchem's WCU410 Copper Controller and WNI Nickel Controller are opto-electronic on-line analyzers that measure the actual concentration of copper or nickel in solution. They are used in a variety of applications including electroless plating baths and microetch baths (including oxide-replacement types).

The WCU410 may be switched from electroless copper to microetch via the menu, eliminating the need for a second controller. It reduces the need for manual titration, improves yield, and in microetch applications improves productivity by reducing the frequency of bath change-outs.

The WNI410 is available as nickel-only, or with a pH control option which may be added in the field. Two separate pump outputs for nickel and reducer and another for pH are used, each of which is capable of totalizing either pump on-time, volume pumped, or metal turnovers.

Integrated datalogging is available to validate system performance. A USB memory stick is all that's needed to extract data and event logs that include copper or nickel measurements, and relay status. Download logs from the USB stick to a PC at your convenience. It couldn't be easier!



### SUMMARY OF KEY BENEFITS



#### Concentration Read in Units

Selectable between grams per liter (g/L) or ounces per gallon (oz/gal). Backlit digital display also acts as a bar graph for a continuous "visual summary" of measurement versus set point.



#### Operator Adjustable

Concentration set point, alarm set points (high and low), dead band and pump on time are all easily adjustable. An interlock feature allows external devices (such as a flow switch ) to interlock control relays.



#### Simple, Integrated Data Collection

Download stored data from the controller to a USB stick. Use the data to simply and easily validate system performance. The data and event logs show copper or nickel values, as well as accumulated chemical feed and relay activation times.



#### Four Separate Control Relays & Outputs (WCU)

May be used to add copper, caustic, formaldehyde or chelator/stabilizer chemistries. Each output has a replenishment totalizer which may be set in units of time or volume.



#### Optional pH Input Board (WNI)

May be used to add pH adjustment chemistry. Output has a replenishment totalizer which may be set in units of time or volume.

## WCU/WNI410 Series | Electroless Copper & Nickel Controllers

### Typical Electroless Copper Application

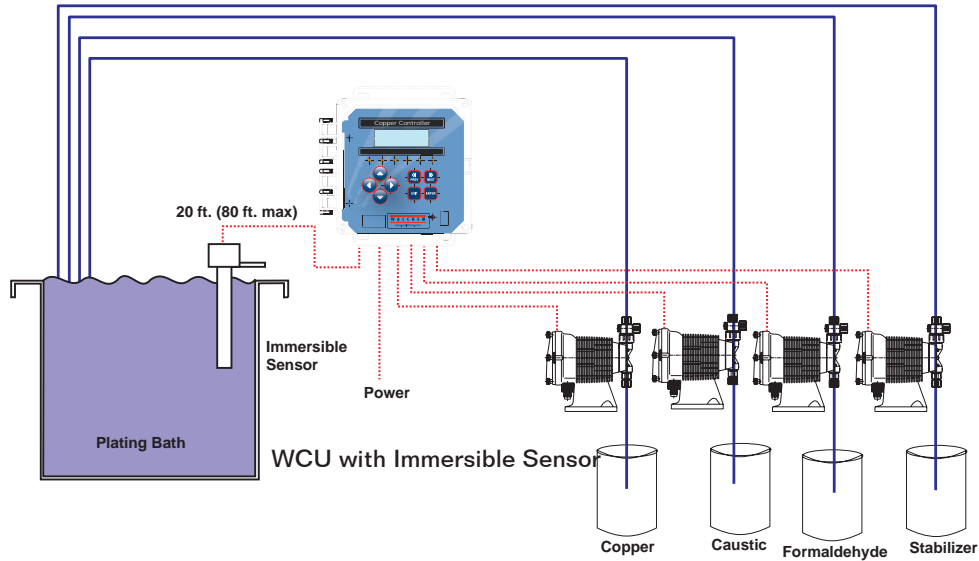

### Typical Electroless Nickel Application without Degasser

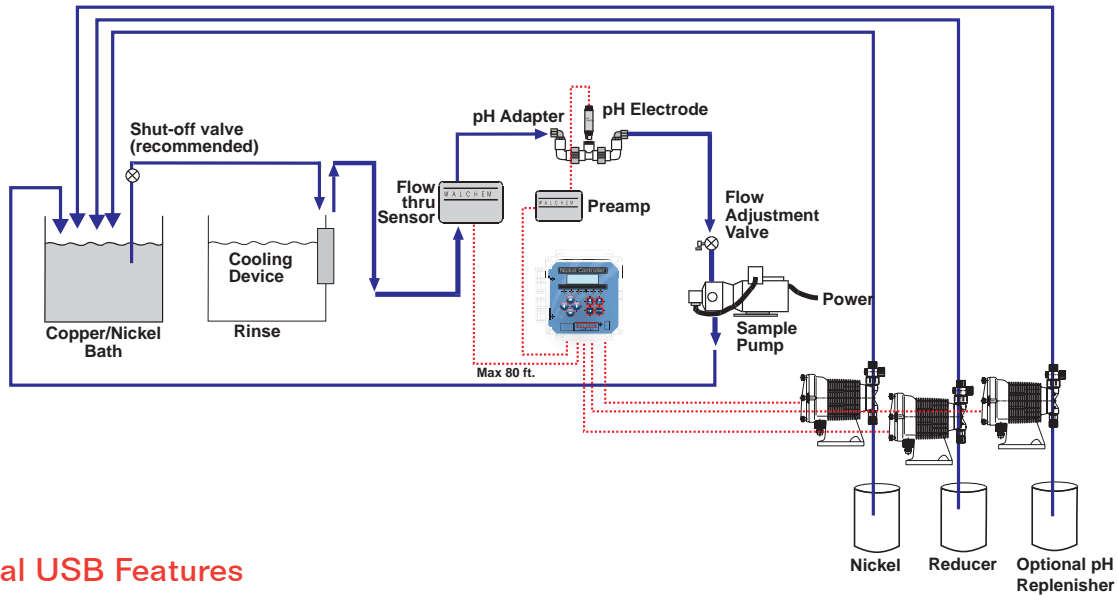

## Optional USB Features

» Integrated datalogging collects analytical measurements at 10 minute intervals and captures all relay activations.

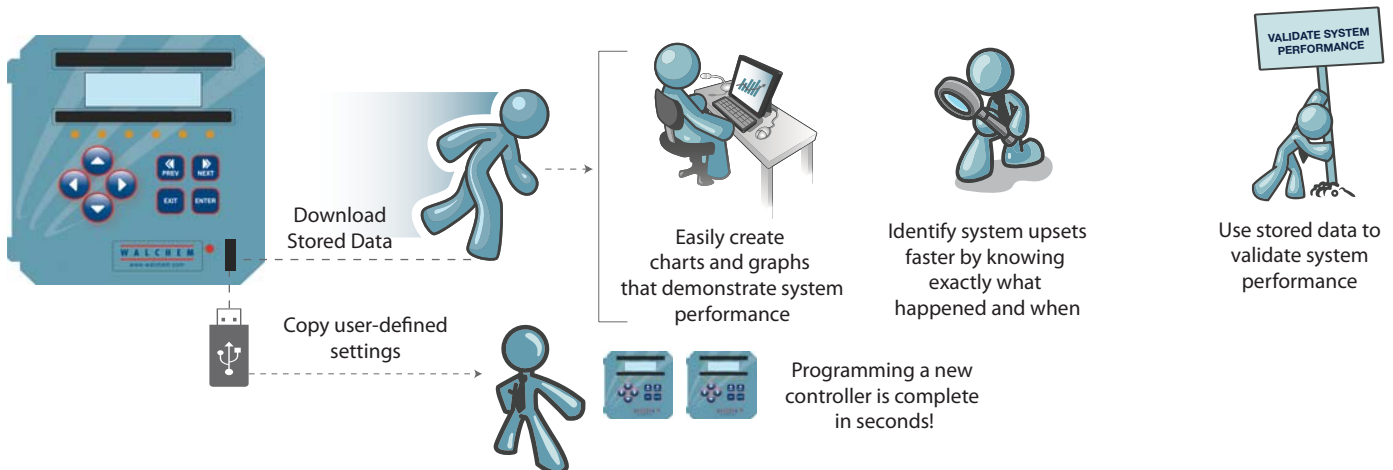

## DIMENSIONS

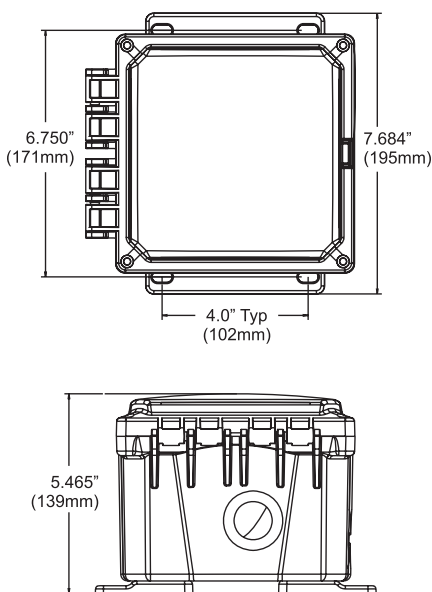

### Flow through sensor

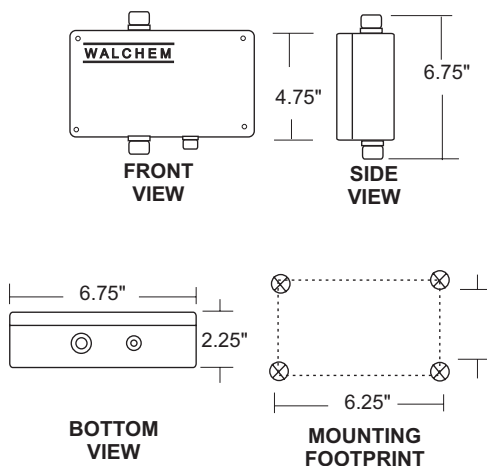

### Immersible sensor

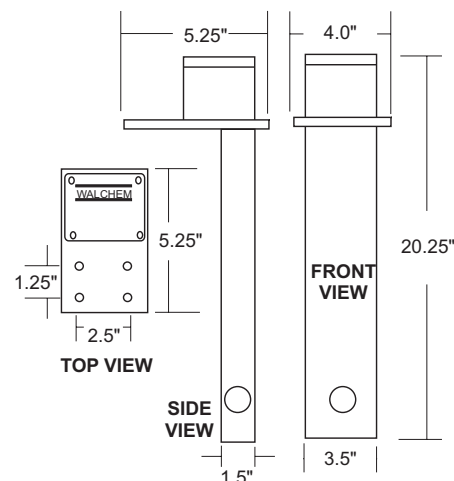

## Inputs

### Power

100-240 VAC, 50/60 Hz, 8A  
Fuse: 1.0 ampere, 5 x 20 mm

### Signals (optional)

WCU: Isolated, dry contact closure required (i.e. flow, level)  
WNI: pH - accepts preamplified pH signal and a Pt100 or Pt1000 RTD for temperature compensation

## Measurement Performance

### WCU

<b>Concentration Range</b>	0.01 to 5.5 g/L (0.001 to 0.73 oz/gal) (Electroless copper)
<b>Range</b>	0.01 to 99 g/L (0.001 to 13.2 oz/gal) (Microetch copper)
<b>Resolution</b>	0.001 g/L (0.0001 oz/gal)
<b>Accuracy</b>	0.01 g/L (0.001 oz/gal)

### WNI

<b>Nickel Concentration Range</b>	0.01 to 10 g/L (0.001 to 1.33 oz/gal)
<b>Accuracy</b>	0.01 g/L (0.001 oz/gal)

<b>pH Range</b>	0 to 14 pH
<b>pH Resolution</b>	0.001 pH
<b>pH Accuracy</b>	±0.01 pH

<b>Temperature Range</b>	0 to 100°C (32 to 212°F)
<b>Temperature Resolution</b>	0.05°
<b>Temperature Accuracy</b>	±0.1°

## Outputs

### Mechanical Relays (5)

Internally powered relays switching line voltage  
6 A (resistive), 1/8 HP  
All relays are fused together in one group, total current for this group must not exceed 6A

### 4 - 20 mA 1 or 2 (optional)

Internally powered  
Fully isolated  
600 Ohm max resistive load  
Resolution .001% of span  
Accuracy ± 1% of reading

## Mechanical

<b>Enclosure</b>	Polycarbonate
<b>NEMA Rating</b>	NEMA 4X (IP65)
<b>Display</b>	2 x 16 character backlit liquid crystal
<b>Ambient Temperature</b>	32 to 122°F (0 to 50°C)
<b>Storage Temperature</b>	-20 to 180°F (-29 to 80°C)
<b>Solution Temperature</b>	WCU: 200°F (93°C) maximum WNI: 212°F (100°C) maximum
<b>Sensor cable</b>	80 ft. maximum, 20 ft. standard
<b>Shipping weight</b>	7 lbs (3 kg) (approximately)

## AGENCY CERTIFICATIONS

UL	ANSI/UL 61010-1:2004, 2nd Edition*
CAN/CSA	C22,2 No.61010-1:2004 2nd Edition*
CE Safety	EN 61010-1 2nd Edition (2001)*
CE EMC	EN 61326 :1998 Annex A*

Note: For EN61000-4-6,-3 the controller met performance criteria B.

\*Class A equipment: Equipment suitable for use in establishments other than domestic, and those directly connected to a low voltage (100-240 VAC) power supply network which supplies buildings used for domestic purposes.

## ORDER INFORMATION

WCU410 —  voltage  output  sensor  USB

WNI41  Dual Input  voltage  output  sensor  USB

### DUAL INPUT

0 = None

1 = pH input\*

### VOLTAGE

1 = 120 VAC, prewired

5 = Hardwired, cable glands

### OUTPUT

N = No 4-20 mA data output

4 = Single Isolated 4-20 mA output

### SENSOR

N = No sensor

1 = Flow through sensor

2 = Immersible sensor (WCU only)

### USB FEATURES

N = Software upgrade capability only

U = Integrated datalogging, event/reset logging, and configuration file import/export

\*WNI: For easy installation, order sensor option "N" plus a 190921 (120VAC) or 190922 (240VAC) sample system when ordering the pH option.



### WebmasterONE®

WebMasterONE is the most powerful online cooling tower/boiler controllers in the water treatment industry. WebMasterONE couples a multi-I/O platform with Walchem's analytical sensors and extensive communications technologies. The result is the ability to remotely monitor and control your process from any computer, anywhere in the world, with just a standard web browser.



### Metering Pumps

Walchem and Iwaki combined their talents to design the most innovative and comprehensive metering pump product line in the world. With over 50 years of combined pump experience, in an array of different markets, the Iwaki-Walchem partnership leverages our strengths to exceed even our toughest customer expectations. Committed to new product development, our pumps are innovative and revolutionary.



### WIND WebMaster Industrial Water Controllers

Walchem's WebMaster® Industrial (WIND) Controller sets a new standard for Industrial Water Treatment Controllers. WIND has a flexible multi-I/O platform, a wide range of analytical sensor measurement capabilities, and an extensive assortment of integrated communications and data handling features.



### WebAlert Remote Monitor

Walchem's WebAlert is the first stand alone remote monitoring device that can web enable your installed equipment without having to replace or upgrade it.

## ABOUT US

Walchem integrates its advanced sensing, instrumentation, fluid pumping and communications technologies to deliver reliable and innovative solutions to the global water treatment market

Our in-house engineering is driven by quality, technology and innovation. For more information on the entire Walchem product line, visit: [www.walchem.com](http://www.walchem.com)



**WALCHEM**  
An Iwaki America Company

Walchem, An Iwaki America Incorporated Company  
Five Boynton Road Hopping Brook Park  
Holliston, MA 01746 USA  
Phone: 508-429-1110  
Fax: 508-429-7433  
[www.walchem.com](http://www.walchem.com)