

WALCHEM

An Iwaki America Company

EZ Series Metering Pumps

EZ Series Electronic Metering Pump Instruction Manual

Five Boynton Road Hopping Brook Park Holliston, MA 01746 USA

TEL: 508-429-1110 FAX: 508-429-7433 WEB: www.walchem.com

Notice

© 2008 WALCHEM, An Iwaki America Incorporated Company (hereinafter "Walchem")
Five Boynton Road, Holliston, MA 01746 USA
tel (508) 429-1110 fax (508) 429-7433
All Rights Reserved
Printed in USA

Proprietary Material

The information and descriptions contained herein are the property of WALCHEM. Such information and descriptions may not be copied or reproduced by any means, or disseminated or distributed without the express prior written permission of WALCHEM.

This document is for information purposes only and is subject to change without notice.

Statement of Limited Warranty

WALCHEM warrants equipment of its manufacture and bearing its identification to be free from defects in workmanship and material for a period of two years from date of delivery from the factory or authorized distributor under normal use and service and otherwise when such equipment is used in accordance with instructions furnished by WALCHEM and for the purposes disclosed in writing at the time purchased, if any. WALCHEM's liability under this warranty shall be limited to replacement or repair, F.O.B. Holliston, MA U.S.A. of any defective equipment or part which, having been returned to WALCHEM, transportation charges prepaid, has been inspected and determined by WALCHEM to be defective.

THIS WARRANTY IS IN LIEU OF ANY OTHER WARRANTY, EITHER EXPRESS OR IMPLIED, AS TO DESCRIPTION, QUALITY, MERCHANT-ABILITY, FITNESS FOR ANY PARTICULAR PURPOSE OR USE, OR ANY OTHER MATTER.

P/N E00159.B1

Nov 2008

TABLE OF CONTENTS

Thank you for choosing a Walchem EZ Series metering pump. This instruction manual deals with the correct installation, operation, maintenance and troubleshooting procedures for the EZ metering pumps. Please read through it carefully to ensure the optimum performance, safety and service of your pump.

1.0	INTRODUCTION.....	1
1.1	Safety and Caution Notes	1
1.2	Principle of Operation.....	1
1.3	Model Code	2
1.4	Specifications	3
1.5	Dimensions	4
2.0	INSTALLATION.....	5
2.1	Unpacking	5
2.2	Location.....	5
2.3	Supply Tubing	6
2.4	Discharge Tubing	7
2.5	Installing Injection/BackPressure Valve	7
2.6	Electrical.....	8
3.0	OPERATION.....	9
3.1	Priming	9
3.2	Adjustment and Control.....	9
3.3	Calibration	13
3.4	STOP Function.....	13
3.5	AC Power Interruption	13
3.6	Auto Air Vent Valve Operation	14
3.7	MultiFunction Valve Operation	15
4.0	MAINTENANCE.....	16
4.1	Diaphragm Replacement	16
4.2	Valve Replacement	16
4.3	Tubing	16
5.0	EXPLODED VIEW & PARTS GUIDE	17
6.0	TROUBLESHOOTING.....	27
7.0	SERVICE POLICY	27

1.0 INTRODUCTION

1.1 Safety and Caution Notes



Always wear protective clothing, eye protection and gloves before working on or near a metering pump. Follow all recommendations of the supplier of the solution being pumped. Refer to the MSDS from the solution supplier for additional precautions.

Walchem EZ Series metering pumps should be installed where ambient temperatures do not exceed 122°F (50°C) or do not fall below 32°F (0°C), or where pump or tubing are directly exposed to sunlight.



WARNING Risk of electrical shock! This pump is supplied with a grounding conductor and grounding-type attachment plug. To reduce the risk of electrical shock, be certain that it is connected only to a properly grounded, grounding type receptacle with ratings conforming to the data on the pump data plate. Prior to performing any maintenance on a pump, disconnect the pump from the electrical power source.



Plumbing Precautions

All tubing must be securely attached to the fittings prior to starting the pump (see Section 2.3). Only use Walchem tubing with your pump. Tubing should be shielded to prevent possible injury in case of rupture or damage. UV resistant tubing should be used if the tubing is exposed to UV light. Always adhere to local plumbing codes and requirements. Be sure that the installation does not constitute a cross connection. Walchem is not responsible for improper installations. Prior to performing any maintenance on a pump, depressurize the discharge tubing.

If you are pumping downhill or into little or no system pressure, a back pressure/anti-syphon device must be installed to prevent over-pumping. Contact your Walchem distributor for additional information.



Solution Compatibility

CAUTION! This pump has been evaluated for use with water only. The suitability of this pump for use with liquids other than water (such as acids or alkalines) is the responsibility of the user. For liquids other than water, select the best-suited liquid end material combination using a chemical compatibility chart.

1.2 Principle of Operation

The EZ series electronic metering pumps consist of a pump unit, a drive unit, and a control unit. The drive unit is an electromagnetic solenoid. When the solenoid coil is energized by the control unit the armature shaft moves forward due to the magnetic force of the solenoid. The shaft is attached to a PTFE faced diaphragm which is part of the pump unit. The diaphragm is forced into the pump head cavity decreasing volume and increasing pressure which forces liquid in the pump head out through the discharge check valves. When the solenoid coil is de-energized, a spring returns the armature to its starting position. This action pulls the diaphragm out of the head cavity increasing volume and decreasing pressure. Atmospheric pressure then pushes liquid from the supply tank through the suction check valves to refill the pump head.

1.3 Model Code

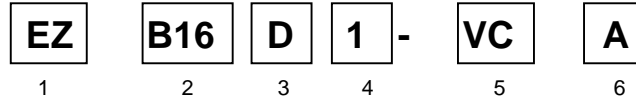

1 Pump Series

EZ Electronic metering pump with manual speed control (adjustable to 360 strokes per minute)

2 Capacity/Pressure Rating (See Section 1.4 for detailed chart.)

3 Control Module

D For use on all EZ models, features digitally adjustable speed and fixed stroke length

T Timer module allows daily, weekly, or 2 week operation with digitally adjustable speed and external stop control. Available on 115V EZB models.

4 Voltage

1 115 VAC, 50/60 Hz

2 230 VAC, 50/60 Hz

5 Liquid End (See Section 1.4 for detailed chart.)

6 Options

M Multifunction Valve is supplied in place of the manual air vent valve. Available for the EZ series pumps with VC, VE, VF, PC and PE liquid ends. Not available with the AAVV feature.

A Auto Air Vent Valve supplied in place of manual air vent valve. Available for the EZ Series in B11, B16, C16 and C21 sizes with –VC liquid ends only.

1.4 Specifications

Electrical	50/60 Hz, single phase		
EZB	115 VAC±10%	0.9 Amp max.	16 watt avg.
	230 VAC±10%	0.4 Amp max.	16 watt avg.
EZC	115 VAC±10%	1.4 Amp max.	24 watt avg.
	230 VAC±10%	0.6 Amp max.	24 watt avg.

Operating Conditions

Ambient temperature	32°F to 122°F (0°C to 50°C)
Relative humidity	30% to 90% non-condensing
Liquid temperature	32° to 104°F (0 to 40°C) for PVC based liquid ends 32° to 140°F (0 to 60°C) for PP, PVDF, SS based liquid ends

Capacity/Pressure Rating

Size	Maximum Output Capacity		Output per Stroke (mL)		Maximum Pressure ¹		Connection Size (in) Tubing O.D
	(Gal/hr)	(mL/min)	Min.	Max.	PSI	MPa	
B11	0.6	38	0.05	0.11	150	1.0	3/8
B16	1.0	65	0.09	0.18	105	0.7	3/8
B21	1.5	95	0.13	0.26	60	0.4	3/8
B31	3.2	200	0.28	0.56	30	0.2	1/2
C16	1.3	80	0.09	0.22	150	1.0	3/8
C21	2.0	130	0.14	0.36	105	0.7	3/8
C31	4.3	270	0.30	0.75	50	0.35	1/2
C36	6.3	400	0.46	1.17	30	0.2	1/2

¹ Auto Air vent valve reduces maximum pressure approx. 35 PSI (0.2 MPa)

Adjustment Range

Frequency adjustment range 0 to 360 strokes per minute

Materials of Construction

Liquid End Code	Pump Head & Fittings	Diaphragm	Valve Balls	Valve Seat	Valve Seals	Gasket	Tubing
PC	GFRPP	PTFE (bonded to EPDM)	CE	FKM	FKM	PTFE	PE
PE	GFRPP		CE	EPDM	EPDM		
VC	PVC		CE	FKM	FKM		
VE	PVC		CE	EPDM	EPDM		
VF	PVC		PTFE	EPDM	EPDM		
TC	PVDF		CE	FKM	FKM		
FC	PVDF		CE	PCTFE	PTFE		

CE	Alumina ceramic	PE	Polyethylene
EPDM	Ethylene propylene diene monomer	PTFE	Polytetrafluoroethylene
FKM	Fluoroelastomer	PVC	Polyvinylchloride (translucent)
GFRPP	Glass fiber reinforced polypropylene	PVDF	Polyvinylidene fluoride
PCTFE	Polychlorotrifluoroethylene		

1.5 Dimensions

EZ Models with thermoplastic liquid end materials

EZB Model Shown for reference

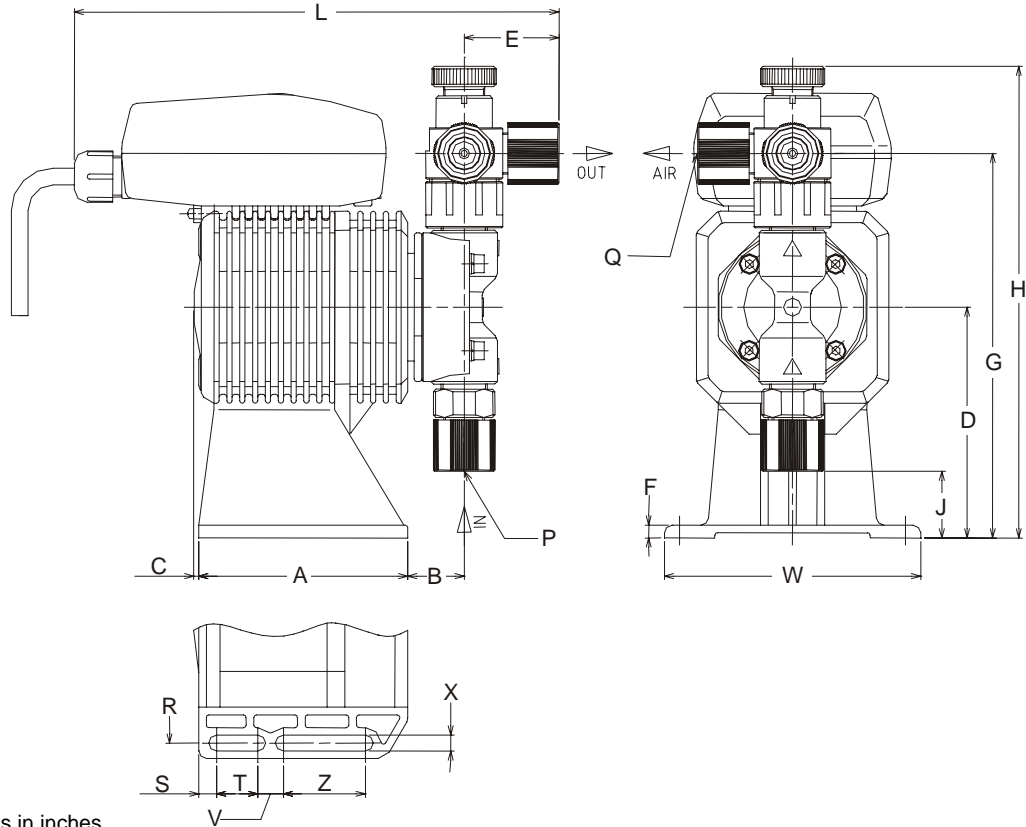

All dimensions in inches

Model		A	B	C	D	E	F	G	H	J	L	P & Q TUBING	W	
EZB	11 16 21	-VC -VE	3.21	0.87	0.08	3.54	1.46 (3.03) ¹ [1.83] ²	0.20	5.91 [6.11] ²	7.24 [8.39] ²	1.02	7.44 (9.53) ¹ [7.81] ²	3/8" O.D.	3.94
		-PC -PE												
		-TC -VF												
	31	-FC	3.21	0.87	0.08	3.54	0.51	0.20	6.09	6.83	1.00	6.50	3/8" O.D.	3.94
		-VC -VE	3.21	1.02	0.08	3.54	0.87	0.20	6.75	8.00	0.32	7.01	1/2" O.D.	3.94
		-PC -PE												
-TC -VF														
-FC	3.21	1.02	0.08	3.54	0.63	0.20	6.85	6.85	0.24	6.77	1/2" O.D.	3.94		
EZC	16 21	-VC -VE	4.13	0.94	---	3.94	1.46 (3.03) ¹ [1.83] ²	0.31	6.30 [6.50] ²	7.64 [8.79] ²	1.42	8.15 (10.24) ¹ [8.52] ²	3/8" O.D.	4.57
		-PC -PE												
		-TC -VF												
	31 36	-FC	4.13	0.94	---	3.94	0.51	0.31	6.48	7.44	1.39	7.20	3/8" O.D.	4.57
		-VC -VE	4.13	1.10	---	3.94	0.87	0.31	7.11	8.37	0.71	7.72	1/2" O.D.	4.57
		-PC -PE												
-TC -VF														
-FC	4.13	1.10	---	3.94	0.63	0.31	7.44	7.44	0.63	7.48	1/2" O.D.	4.57		

¹ Dimension with automatic air vent valve option

² With Multifunction valve

Mounting Dimensions	R	S	T	X	V	Z
EZB all variations	3.46	0.28	0.63	0.24	0.39	1.26
EZC all variations	3.94	0.59	1.18	0.28	0.59	1.18

2.0 INSTALLATION

2.1 Unpacking

Open the shipping carton and inspect contents for damage. If any items are missing or damaged contact your local distributor.



Pumps are pre-primed with water at the factory. If the application is not compatible with water, drain and dry before use. Be sure to remove caps from fittings before attaching tubing.

CAUTION: Head bolts may have loosened during storage or shipment. Be sure to check and tighten to 19 lb-in torque, if necessary.

Do not handle or move the pumps using the Control Module only. The pump should be supported by the base or drive unit during handling

2.2 Location

Choose a location for the pump which is clean, dry, close to an electrical outlet, and allows convenient access to stroke length control, frequency control, and tubing connections. Avoid areas where ambient temperature exceeds 122°F (50°C) or falls below 32°F (0°C), or where the pump or tubing would be exposed to direct sunlight.

This pump is cord connected and not intended for permanent mounting to a building structure. However, temporary mounting to stabilize the pump during operation may be necessary as long as tools are not required for the installation or removal of the pump.

Flooded suction (mounting the pump below the level of liquid in the supply tank) is strongly recommended, especially when pumping liquids that readily generate gas bubbles. Sodium hypochlorite and hydrogen peroxide are common examples of such liquids. (See Figure 1.)

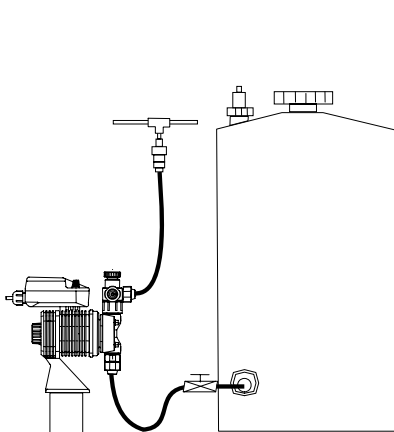

Figure 1
Flooded Suction

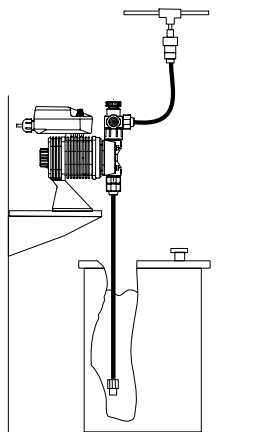

Figure 2
Shelf Mount

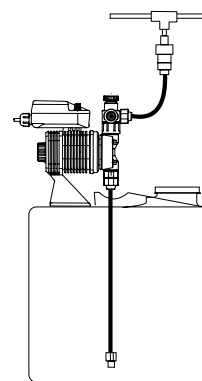

Figure 3
Tank Mount

If flooded suction mounting is not possible, a shelf adjacent to (but not directly above) the supply tank often works well. (See Figure 2.) The supply tank or cover can also be used if it has provisions for mounting a pump. (See Figure 3.) In any case, the total suction lift should not exceed 5 ft (1.5m).

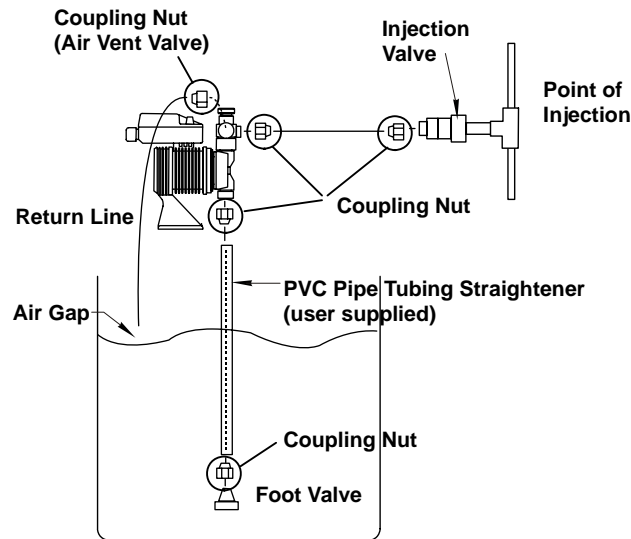

Figure 4 Tubing Connections

2.3 Supply Tubing

The supply tubing run should be as short as possible. For flooded suction mounting, install a shut-off valve with an appropriate tubing connector at the tank outlet. Cut a length of tubing from the coil supplied and install between the shut-off valve and the pump inlet fitting. For suction lift applications, slide on the ceramic weight, then install a foot valve on one end of suction tubing. Cut the tubing to a length such that the foot valve hangs vertically about 1 in (25mm) above the bottom of the tank. Avoid any loops in the tubing run that could form a vapor trap. Running the tubing through a length of pipe will help to keep tubing straight. Total vertical suction lift should be no more than 5ft. (1.5m). Reference Figure 4.

Attach tubing as shown in Figure 5. First slide the coupling nut, small end first, onto the tubing. Push the tubing over the valve housing tip *all the way to the valve housing shoulder*. (Tip: if the tubing is stiff from cold, dip the tubing end in hot tap water for a few minutes so it will slide on and flare out more easily. Push the coupling nut onto the threads. Apply some pressure on the coupling nut and tubing while tightening the nut, making sure the tubing has not backed off of the shoulder of the valve housing.

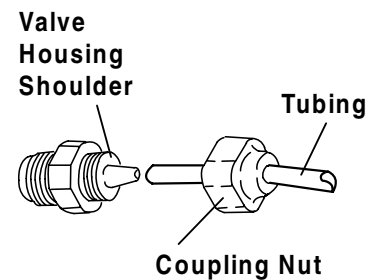

Figure 5



WARNING: *All fittings and coupling nuts should be tightened by hand only. If necessary, a small tool may be used to make it snug. DO NOT use excessive force or large wrenches.*

The coupling nut should not bottom out completely against the fitting. If this happens during connection, either the tubing has slid down the shoulder while tightening, or the tubing has been pinched. Remove the coupling nut, re-cut the tubing and re-connect.



WARNING: *If there is any leakage around the coupling nut and it appears to have been installed correctly, DO NOT TIGHTEN the coupling further! Release pressure in the line, disconnect tubing, re-cut and re-connect. Tightening of misinstalled tubing may cause the tubing to pop off under pressure.*

2.4 Discharge Tubing

Cut a length of tubing long enough to go from the pump to the application (injection) point. Additional tubing can be ordered from your distributor. Avoid sharp turns or bends and hot surfaces. Routing tubing through rigid pipe such as PVC pipe is recommended for long runs and/or as protective shielding against corrosive chemicals. If applicable, install the injection valve in 1/2" NPT thread at the injection point (see section 2.5) and connect the discharge tubing to the injection valve.

Attach tubing as described in section 2.3 and as shown in Figures 5 and 6. Note: Some models have an air vent valve with two outlet connections. The connection marked 'OUT' is the discharge side to the application point. (Fig 6).

Attach a second length of tubing to the air vent side marked ('AIR') and route back to the chemical solution tank or drum. On the larger pumps (31 & 36 sizes), the air vent valve connections are not marked, however, the discharge side is the vertical (UP) connection and the air vent connection is on the side of the valve.

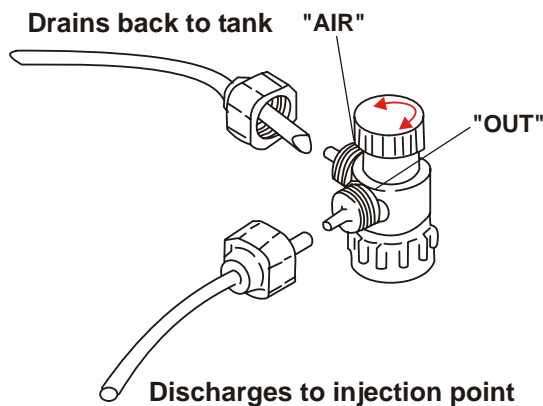

Figure 6 Air Vent Valve Tubing

2.5 Installing Injection/BackPressure Valve

A fitting or tee with 1/2" NPTF threads and with sufficient depth will accept the injection valve assembly. If required, trim off an amount of the extension tip until it fits your fitting or tee. (Fig. 7.)

The position of the injection/back pressure valve can be at any orientation as long as the spring is retained in the valve. **DO NOT REMOVE THE SPRING.** Be sure to check and replace the spring as needed. Attach the tubing following the same instructions in section 2.3, connecting the supply tubing.

CAUTION: Some chemicals may have reactions as they are injected into the main flow. For example, sulfuric acid may react with water causing excess heat. If the chemical is heavier than water, mount the injection valve as close as possible to vertical coming into the bottom of the pipe. This will keep the injection nozzle facing up and keep the heavier chemistry from draining into the pipe and causing adverse reactions within the injection valve and pipe.

In addition to preventing backflow from pressurized lines, the injection valve acts as a back pressure valve when pumping into atmosphere or low pressure applications. However, the back pressure by the injection valve can vary and the valve does NOT act as an anti-siphon valve. If siphoning is a possibility, or if pumping downhill into open atmosphere (open tank), a Walchem MultiFunction valve or a separate back pressure/anti-siphon valve must be installed.

Note: Siphoning can also occur at the tip of the injection valve because of the high flow rate in the main pipe flowing past the small injection nozzle (venturi effect). In this case, an anti-siphon device must be installed to avoid over feeding or siphoning of chemistry.

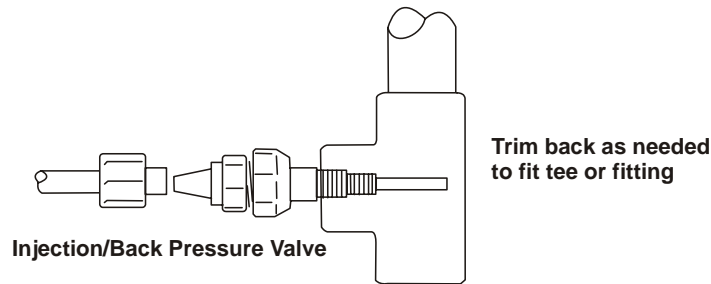

Figure 7 Injection Valve

See Section 5.0 for complete liquid ends parts list and exploded view.

2.6 Electrical



WARNING Risk of electrical shock! *This pump is supplied with a grounding conductor and grounding-type attachment plug. To reduce the risk of electrical shock, be certain that it is connected only to a properly grounded, grounding type receptacle.*

Connect the pump power cord to a **GROUND**ED outlet supplying proper voltage. Avoid branch circuits that also supply power to heavy machinery or other equipment that could generate electrical interference.

3.0 OPERATION

3.1 Priming

Install the pump as described above. With the pump turned on, set frequency at 100%. If the pump is equipped with an air vent valve, open the knob 1/2 turn. Liquid should move through the suction tubing and into the pump head. When liquid starts running through the vent side tubing, close the air vent knob and continue with output adjustment described below. If the pump has no air vent valve, disconnect the discharge tubing from the injection valve. When liquid enters the discharge tubing at the pump head, stop the pump. Then reconnect the discharge tubing to the injection valve.

If the pump does not self prime, remove the check valve housing on discharge & suction sides to make sure valve cartridges and gaskets are in correct positions (see section 4.2 for correct orientation).

Note: It is recommended that pumps with FC liquid ends use flooded suction when priming, due to the hard valve seat material.

3.2 Adjustment and Control

A. EZ Pumps using the 'D' Control Module

If less than full output is required, set the frequency to the appropriate percentage of maximum desired.

Example: Model EZB21D1-VE has maximum output of 1.5 GPH.

Desired output is 1.2 GPH. $1.2 \div 1.5 = 0.8$ or 80%

Set the frequency of the pump to $0.8 \times 360 = 288$ spm by pushing the UP or DOWN arrow keys.

B. EZ Pumps using the 'T' Control Module

The EZB-Timer Series is able to operate in Daily, Weekly and 2-Week modes. An external stop input and 12VDC output are also available.

Display/Keypad Overview

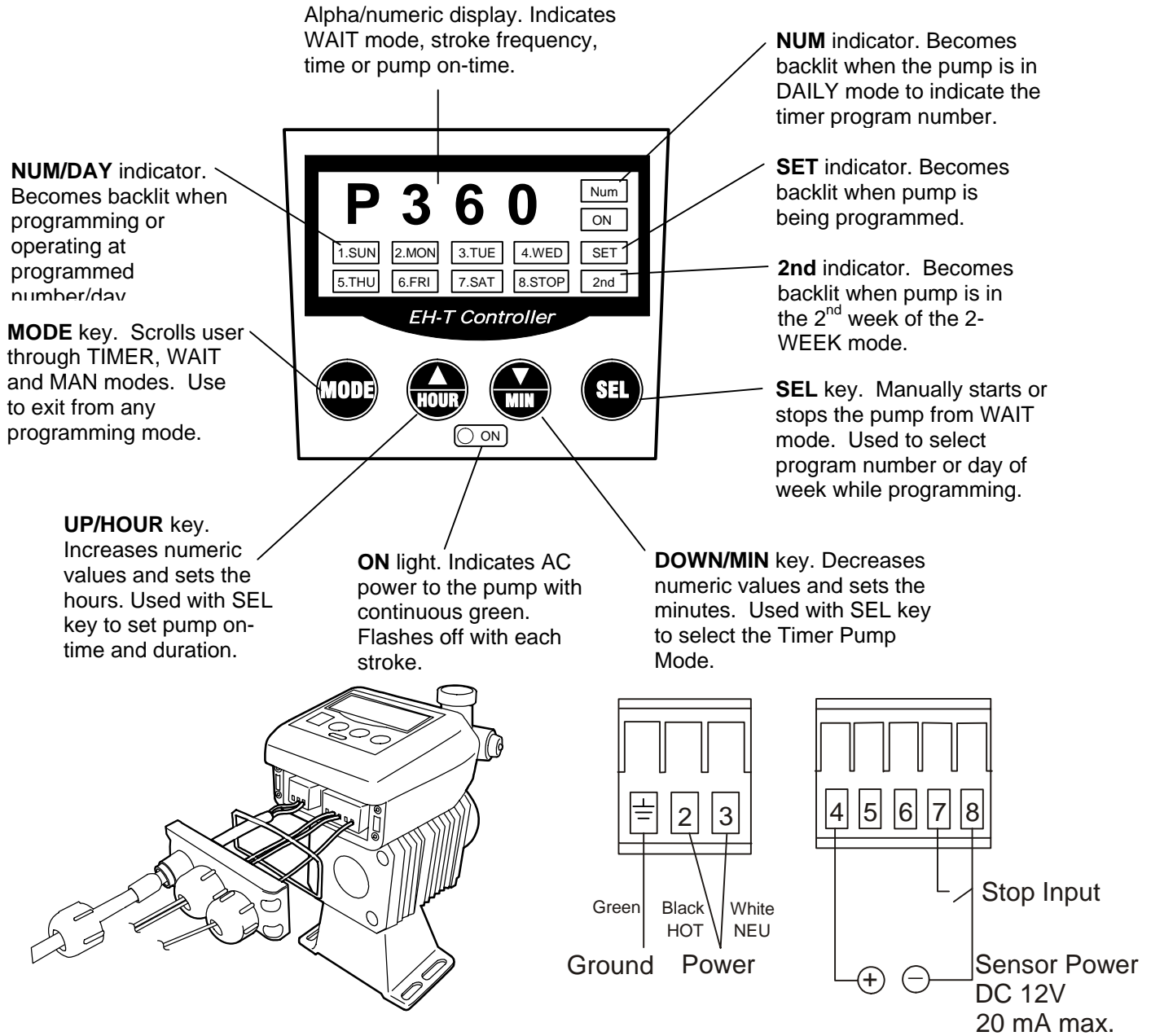

Figure 8

EZ-T Quick Reference Guide

(MODE) Mode Key

(SEL) Select Key

FROM:	PRESS:	TO:
TIMER RUN MENU	(MODE)	Move to WAIT menu
WAIT MENU	(MODE)	Move to MANUAL menu
	(SEL) (Hold for 3 seconds)	Move to TIME / DATE setting menu
	(SEL) + (▲) HOUR	Move to TIMER programming menu
	(SEL) + (▼) MIN	Move to TIMER MODE selection menu
MANUAL MENU	(MODE)	Move to TIMER RUN mode (shows TIME)
	(SEL)	Starts and stops manual operation
	(▼) MIN OR (▲) HOUR	Changes pump frequency (1 to 360 SPM)
TIME / DATE MENU (24 Hour Clock)	(▲) HOUR	Sets the Hour (incrementing only)
	(▼) MIN	Sets the Minutes (incrementing only)
	(SEL)	Selects the Day of the week
	(MODE)	Exits back to WAIT menu
TIMER MODE MENU	(▲) HOUR OR (▼) MIN	Scrolls between DAILY, WEEK or 2-WEEK Timer modes
	(MODE)	Exits back to WAIT menu
TIMER PROGRAMMING MENU	(▲) HOUR	Sets the Hour / Sets On-Time Minutes
	(▼) MIN	Sets the Minutes / Sets On-Time Minutes
	(SEL)	Scrolls through the week days / program #
	(MODE)	Exits back to WAIT menu

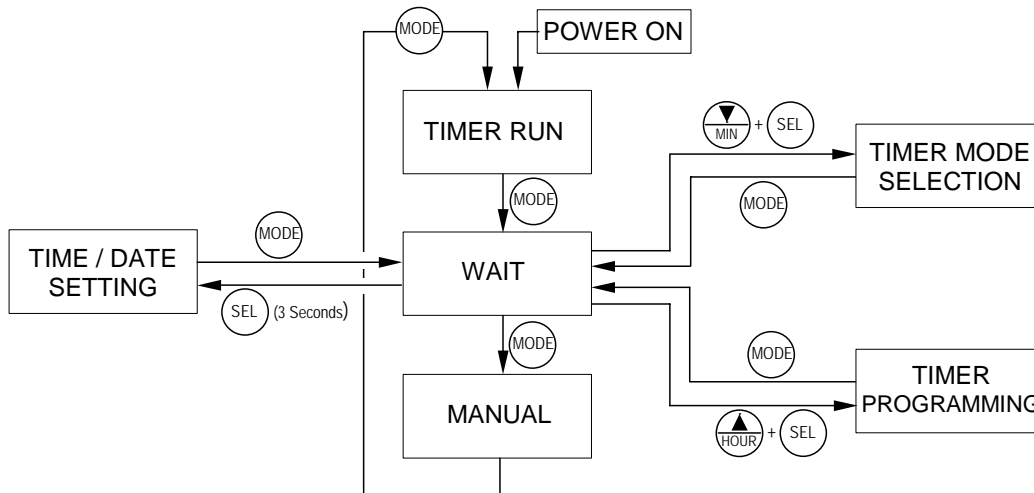

Programming and Timer Use

CAUTION! Before use, check the time and date. Set to the local time and date before programming. Incorrect time/date can result in incorrect operation.

1. Manual Operation

From the WAIT menu, pressing the MODE key will enter the manual mode. Pressing SEL will toggle the pump on and off manually. The speed can be changed with the UP and DOWN arrows both running and waiting. **NOTE: The pump speed set in this menu will be the speed that the pump will run during timed operations.**

2. Time/Date Setting

From the WAIT menu, holding the SEL key down for 3 seconds will enter into the Time/Date SET menu. Using the HOUR and MIN keys, the time can be set using a 24-hour clock. The SEL key will cycle through the days of the week. Once the correct time and day of the week are set, pressing the MODE key will go back to the WAIT menu.

3. Timer Mode Selection

Pressing the MIN and SEL keys at the same time will bring up the Mode Selection menu. This menu is where the Timer module is set to control in daily, weekly, or in 2-week modes. Use the UP and DOWN keys to cycle through the three options and MODE to get back to the WAIT menu. Daily mode allows a max of up to 8 timed operations repeated every day. Weekly and 2-week modes allow a max of one timed operation per day.

4. Timer Operation Programming

Pressing the HOUR and SEL keys at the same time will bring up the Timer Programming menu. This menu is where the individual operations are set – both start time and run time.

DAILY MODE:

Initially, the 1-SUN and NUM will both be backlit. NUM is backlit to signal that the number backlit is used – i.e. program 1 in this case. Using the HOUR and MIN keys, the time for the first program can be set (24-hour clock). Pressing the SEL key will change the menu to program the on-time to run the pump (initially shows “ 0M”). Use the UP and DOWN keys to program the # of minutes for the pump to run. Pressing SEL again will then move to program the second program and the backlight will move from 1-SUN to 2-MON. The clock and on-time settings are set in the same manner. Pressing MODE will go back to the WAIT menu.

WEEKLY MODE:

Initially, the 1-SUN will be backlit signifying that Sunday is being programmed. If a program is desired for Sunday, use the HOUR and MIN keys to set the time of the program. If no program is desired for Sunday, pressing the SEL key will scroll through each day’s two programmed settings – the time to start and the run time. Pressing MODE will go back to the WAIT menu at any point in the programming.

2-WEEK MODE:

Two week mode is similar and set just as the weekly mode, only after the first 7-SAT is programmed or passed by and 1-SUN is again backlit, the “2nd” will also become backlit showing that the day is in the 2nd week. All programming functions are the same and SEL will scroll through each setting. Pressing MODE will go back to the WAIT menu at any point in the programming.

From the WAIT mode, pressing MODE will move to the MANUAL menu. Check to make sure that the pump speed is set at the rate desired during the timed operations. If not, use the UP and DOWN keys to change the pump speed.

Pressing MODE again will display the current time and date. The pump is now operating in the TIMER mode and will come on at the next programmed timer operation.

3.3 Calibration

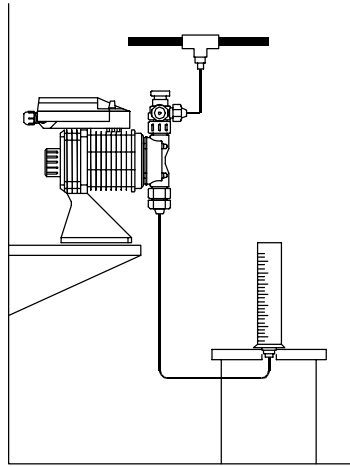

Figure 9 Calibration

If exact output calibration is required, first prime and adjust the pump as above. Then connect a calibration column to the suction side of the pump. Turn the pump on for one minute and read the amount of liquid pumped from the column. Adjust the frequency up or down as necessary and check the output again. When the desired output is reached, disconnect the calibration column and reconnect the suction tubing. (See Figure 9) Calibration must be performed with application equivalent back pressure for accurate results.

3.4 STOP Function

Additionally, EZ pumps with a Timer Module can be controlled in start-stop mode. In this mode, AC power is applied continuously and pump operation is stopped by completing the circuit between the positive 'stop' and common terminals inside the T Control Module: 7 (positive) and 8 (common). A switch or solid state device capable of switching 5VDC at 2 mA should be used. Switch closed = pump stopped, switch open = pump running at the speed determined by the frequency setting. This feature eliminates the need for a high voltage, high current AC relay to start and stop the pump. (See Figure 8)

3.5 AC Power Interruption

If AC power is interrupted, the pump will power up as shown below:

State preceding power OFF	State following power ON
WAIT	WAIT
Running in Manual Operation	Running in Manual Operation
Running in Timer Operation	Running in Timer Operation
Setting Time	WAIT
Programming Timer Set points	WAIT

3.6 Auto Air Vent Valve Operation

The Auto Air Vent Valve is an option on select EZ pumps and replaces the standard Manual Air Vent Valve when ordered. It is used primarily in applications where gassing is a problem and pumps can lose prime.

Unlike the Manual Air Vent Valve, the Auto Air Vent Valve constantly bleeds a controlled amount of volume out of the “Air” vent. Therefore, the “Air” vent should *always* be plumbed back to the source tank. During priming, the access knob does not have to be loosened as with a manual air vent valve as pressure is relieved through the vent. The Top Valve Guide assembly uses a bottom seat to ensure that air is not introduced into the discharge media and utilizes a precisely machined top seat that allows air to be quickly purged but limits the amount of liquid returned to the tank. A sleeve valve is used to maintain backpressure within the pump head, which helps speed the purging of air.

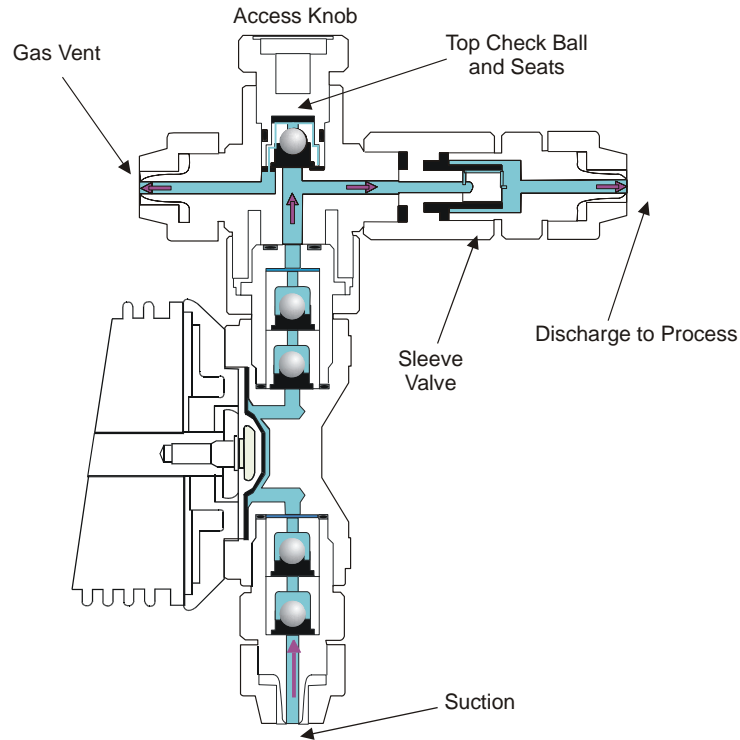

AAVV – Cross Sectional View

3.7 MultiFunction Valve Operation

The MultiFunction Valve is optional on select EZ pumps and replaces the standard Manual Air Vent Valve when ordered. It integrates the air venting/bleeding functions with a back pressure and anti-siphon valve.

Air Vent / Bleed Function

1. Open the air vent by turning the air vent adjustment knob counter-clockwise one to one and a half turns.
2. Operate the pump until all of the air is purged and only liquid is discharged from the air vent drain.
3. Turn the air vent adjustment knob clockwise until it bottoms out and will not turn further.

Back Pressure / Anti-Siphon Valve

1. A spring-loaded diaphragm automatically adds 30PSI of back pressure to the discharge side of the pump when the air vent adjustment knob is closed.
2. If back pressure is not observed, the pressure release knob may be in the release position (the knob is resting in its 'up' location). If this is the case, turn the knob clockwise until it 'clicks' down (approximately $\frac{1}{4}$ turn).
3. The diaphragm prevents siphoning of chemical through the pump.

Pressure Release

1. Stop the pump operation.
2. Turn the pressure release knob clockwise until it 'clicks' into the release or 'up' location (approximately $\frac{1}{4}$ turn). If the knob is turned too far, it will 'click' again return to the back pressure or 'down' position. If this happens, keep turning the knob clockwise until it 'clicks' one time in the release ('up') position.
3. Turn the air vent adjustment knob counter-clockwise one or one and a half turns to release the pressure in the discharge tubing/piping through the air vent drain. The air vent drain should always be plumbed back to the supply tank or to safe disposal. Do not submerge the air vent drain tubing under chemical in the supply tank.

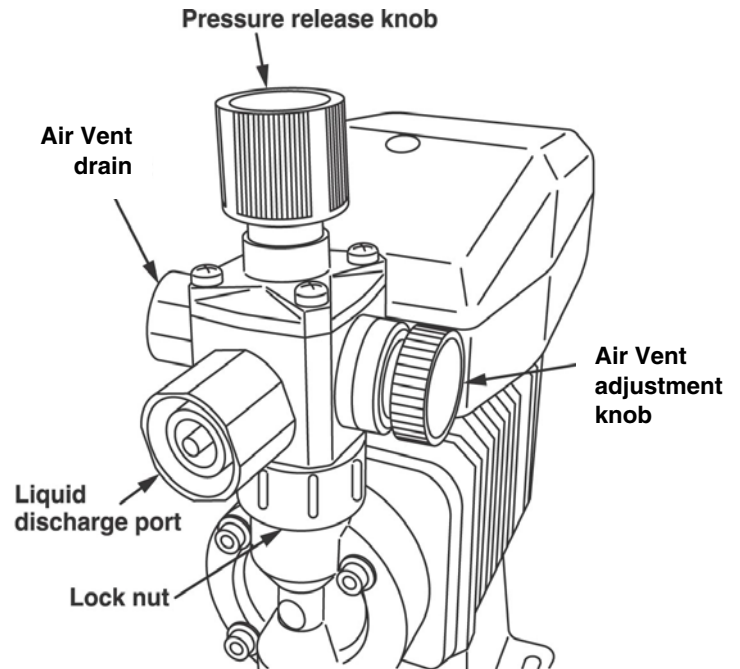

CAUTION: Confirm that liquid is discharged from the air vent drain. If the liquid is not discharged, the pressure may not be released. If this is the case, repeat the Pressure Release procedure.

4.0 MAINTENANCE



CAUTION: Before working on the pump, disconnect the power cord, depressurize the discharge tubing and drain or flush any residual liquid from the pump head and valves. Always wear protective gear when working around chemicals.

4.1 Diaphragm Replacement

Disconnect AC power to the pump and disconnect the suction tubing, discharge tubing, and air vent tubing. Remove the four head bolts with a 4mm or 5mm hex wrench. Turn the stroke length knob fully counter-clockwise. Unscrew the diaphragm and remove its retainer (small disk behind the diaphragm). **CAUTION:** *There may be small brass spacers between the retainer and the armature shaft. These spacers need to be reused when replacing the diaphragm.* Install the new retainer and diaphragm on the shaft. Turn the diaphragm clockwise until it bottoms on the shaft. Replace the pump head and tighten the head bolts to a torque of 19 lb-in (2.16 N-m).

4.2 Valve Replacement

Remove the suction and discharge tubing making sure discharge side has been depressurized. Remove the suction fitting, two valve cartridges, o-ring and gasket(s). Install the new o-ring, gasket(s) and valve cartridges. Be sure both valve seats are in the same orientation. Refer to Figure below. Tighten the suction fitting. Similarly remove and replace the discharge valve cartridges, o-ring and gasket(s). For a more detailed drawing, refer to the Section 6.0.

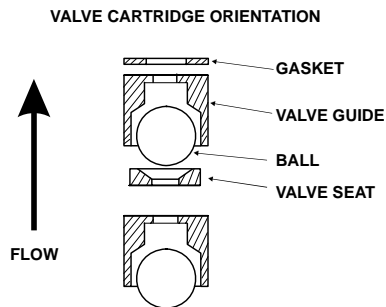

Valve Cartridge Orientation

CAUTION: *There are many small parts in the liquid end. These parts must be installed correctly for proper operation of the pump.*



4.3 Tubing

Check ends of tubing for splits, cracks, or thin spots. Examine the full length of tubing for damage due to chafing, abrasion, stress cracks, excessive temperature or exposure to ultraviolet light (direct sunlight or mercury vapor lamps). If any signs of deterioration exist, replace the entire length of tubing. It is a good idea to replace discharge tubing on a regular preventive maintenance schedule every 12 months.

5.0 EXPLODED VIEW & PARTS GUIDE

PVC/GFRPP Liquid End Exploded View #1

For EZ pump model sizes 11, 16, and 21

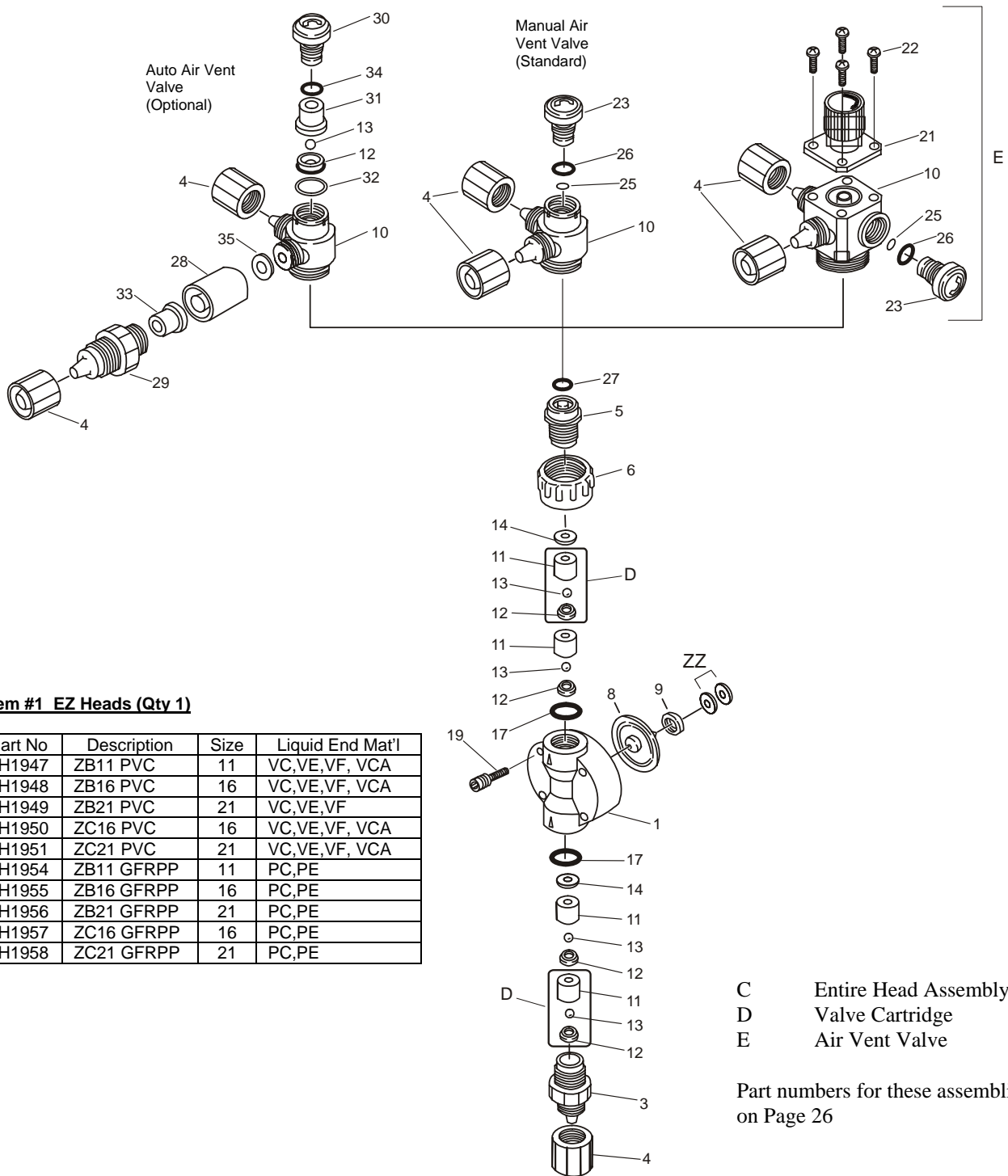

PVC/GFRPP Liquid End Exploded View #1

Components

Item	Part No	Description	Qty	Size	Liquid End Mtl
3	EH0400	Housing, Valve, 3/8 PVC	1	11, 16, 21	VC, VE, VF, VCA
	EH0418	Housing, Valve, 3/8 GFRPP	1	11, 16, 21	PC, PE
4	EH0401	Nut, Coupling, 3/8 PVC	3	11, 16, 21	VC, VE, VF, VCA
	EH0419	Nut, Coupling, 3/8 GFRPP	3	11, 16, 21	PC, PE
5	EH0294	Fitting, Air Vent, PVC	1	11, 16, 21	VC, VE, VF, VCA
	EH0315	Fitting, Air Vent, GFRPP	1	11, 16, 21	PC, PE
6	EH0295	Nut, Lock, Air Vent, PVC	1	11, 16, 21	VC, VE, VF, VCA
	EH0316	Nut, Lock, Air Vent, GFRPP	1	11, 16, 21	PC, PE
* 8	EH1971	Diaphragm, Z11	1	11	all
	EH1972	Diaphragm, Z16	1	16	all
	EH1973	Diaphragm, Z21	1	21	all
* 9	EH0059	Retainer, Z11	1	11	all
	EH0083	Retainer, Z16	1	16	all
	EH0067	Retainer, Z21	1	21	all
10	EH0402	Body, Manual Air Vent, PVC	1	11, 16, 21	VC, VE, VF
	EH0420	Body, Manual Air Vent, GFRPP	1	11, 16, 21	PC, PE
	EH0861	Body, Auto Air Vent, PVC	1	11, 16, 21	VCA
	EH1406	Body, Multifunction Valve, PVC	1	11, 16, 21	VCM, VEM, VFM
	EH1407	Body, Multifunction Valve, GFRPP	1	11, 16, 21	PCM, PEM
* 11	EH0060	Guide, Valve, .188 PVC	4	11	VC, VE, VF, VCA
	EH0318	Guide, Valve, .188 GFRPP	4	11	PC, PE
	EH0068	Guide, Valve, .250 PVC	4	16, 21	VC, VE, VF, VCA
	EH0325	Guide, Valve, .250 GFRPP	4	11, 21	PC, PE
* 12	EH0061	Seat, Valve, .188 FKM	4 (5)	11	VC, PC (VCA)
	EH0048	Seat, Valve, .188 EPDM	4	11	VE, PE, VF
	EH0069	Seat, Valve, .250 FKM	4	16, 21	VC, PC
	EH0071	Seat, Valve, .250 EPDM	4	16, 21	VE, PE, VF
* 13	EH0025	Ball, Valve, .188 CE	4 (5)	11	VC, VE, PC, PE, (VCA)
	EH0084	Ball, Valve, .250 CE	4	16, 21	VC, VE, PC, PE, VCA
	E00063	Ball, Valve 0.188 PTFE	4	11	VF
	E00064	Ball, Valve 0.250 PTFE	4	16, 21	VF
* 14	EH0026	Gasket, Valve, .188 & .250 PTFE	2	11, 16, 21	VC, VE, VF, VCA
	EH0580	Gasket, Valve, .188 & .250 PTFE	2	11, 16, 21	PC, PE
* 17	EH0027	O-Ring, S14 FKM	2	11, 16, 21	VC, PC, VCA
	EH0050	O-Ring, S14 EPDM	2	11, 16, 21	VE, PE, VF
19	EH1987	Bolt, M4 x 40 w/PW & SW, 316SS	4	B11, 16, 21	all
	EH1986	Bolt, M4 x 35 w/PW & SW, 316SS	4	C16, 21	all
21	E90374	Multifunction Valve Top Asm	1	11, 16, 21	all xxM ends
22	EH1410	Screw, M4 x 10, SS304, PP	4	11, 16, 21	all xxM ends
23	EH0299	Knob, Manual Air Vent Valve, PVC	1	11, 16, 21	VC, VE, VF
	EH0321	Knob, Manual Air Vent Valve, GFRPP	1	11, 16, 21	PC, PE
* 25	EH0300	O-Ring, P4 FKM	1	11, 16, 21	VC, PC, VCA
	EH0301	O-Ring, P4 EPDM	1	11, 16, 21	VE, PE, VF
* 26	EH0302	O-Ring, P10A FKM	1	11, 16, 21	VC, PC, VCA
	EH0303	O-Ring, P10A EPDM	1	11, 16, 21	VE, PE, VF
* 27	EH0304	O-Ring, P7 FKM	1	11, 16, 21	VC, PC, VCA
	EH0305	O-Ring, P7 EPDM	1	11, 16, 21	VE, PE, VF
28	EH0864	Fitting, Adapter, AAVV, PVC	1	11, 16, 21	VCA
29	EH0867	Fitting, AAVV, PVC	1	11, 16, 21	VCA
30	EH0774	Knob, AAVV, PVC	1	11, 16, 21	VCA
31	EH0862	Guide, Valve, AAVV, Titanium	1	11, 16, 21	VCA
32	EH0775	Spacer, AAVV, PVC	1	11, 16, 21	VCA
33	EH0865	Tube, Valve, AAVV, FKM	1	11, 16, 21	VCA
34	EH0776	O-Ring, S12, FKM	1	11, 16, 21	VCA
35	EH0866	Gasket, AAVV, FKM	1	11, 16, 21	VCA
ZZ	-----	Brass Spacers		Drive specific/Reuse when replacing diaphragm	
* ZZ		Included in spare parts kit			

PVC/GFRPP Liquid End Exploded View #2
 For EZ pump model sizes 31 and 36

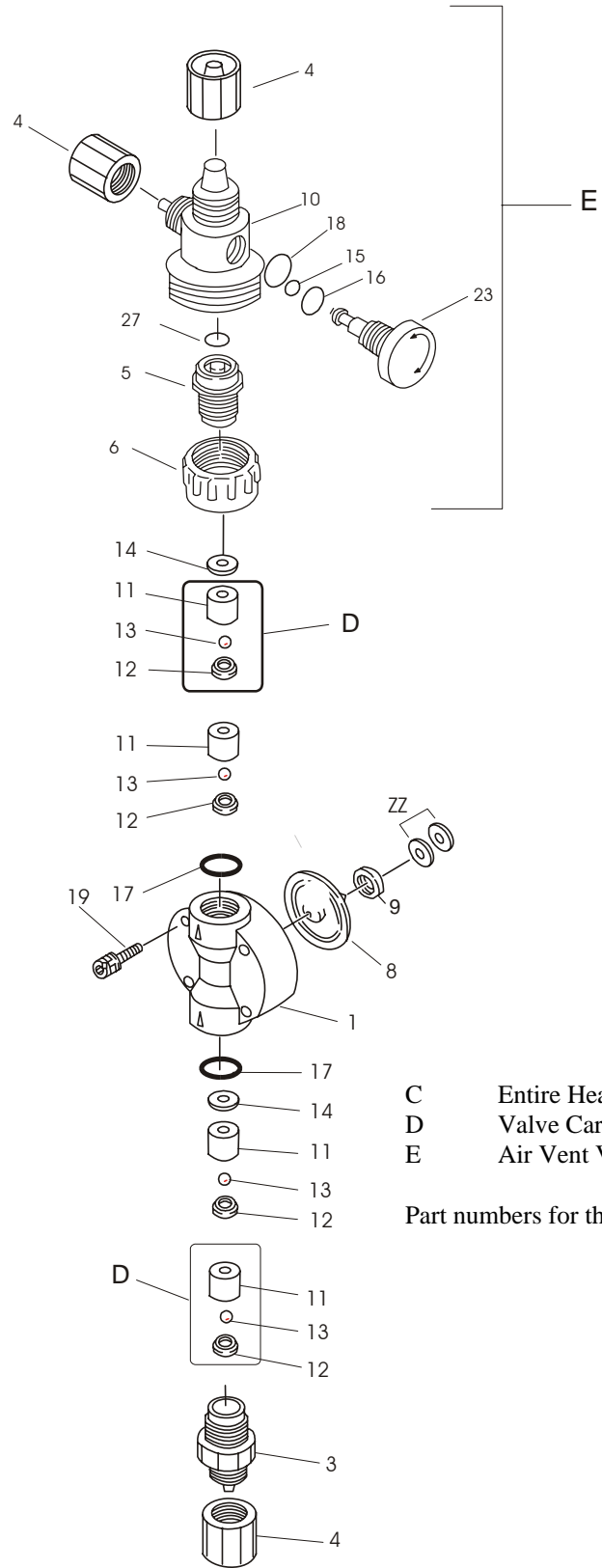

- C Entire Head Assembly
- D Valve Cartridge
- E Air Vent Valve

Part numbers for these assemblies are on Page 26

PVC/GFRPP Liquid End Exploded View #2

Components

Item	Part No	Description	Qty	Size	Liquid End Mtl
1	EH1952	Head, ZB31, PVC	1	31	VC, VE, VF
	EH1960	Head, ZC31, PVC	1	31	VC, VE, VF
	EH1953	Head, ZC36, PVC	1	36	VC, VE, VF
	EH1959	Head, ZB31, GFRPP	1	31	PC, PE
	EH1961	Head, ZC31, GFRPP	1	31	PC, PE
	EH1962	Head, ZC36, GFRPP	1	36	PC, PE
3	EH0405	Housing, Valve, 1/2 PVC	1	31, 36	VC, VE, VF
	EH0421	Housing, Valve, 1/2 GFRPP	1	31, 36	PC, PE
4	EH0406	Nut Coupling, 1/2 PVC	3	31, 36	VC, VE, VF
	EH0422	Nut, Coupling, 1/2 GFRPP	3	31, 36	PC, PE
5	EH1078	Fitting, Air Vent, PVC	1	31, 36	VC, VE, VF
	EH1088	Fitting, Air Vent, GFRPP	1	31, 36	PC, PE
6	EH1077	Nut, Lock, Air Vent, PVC	1	31, 36	VC, VE, VF
	EH1087	Nut, Lock, Air Vent, GFRPP	1	31, 36	PC, PE
* 8	EH1974	Diaphragm, Z31	1	31	all
	EH1975	Diaphragm, Z36	1	36	all
* 9	EH0087	Retainer, Z31	1	31	all
	EH0158	Retainer, Z36	1	36	all
10	EH1101	Body, Manual Air Vent, PVC	1	31, 36	VC, VE, VF
	EH1099	Body, Manual Air Vent, GFRPP	1	31, 36	PC, PE
* 11	EH0118	Guide, Valve, 0.375 PVC	4	31, 36	VC, VE, VF
	EH0332	Guide, Valve, 0.375 GFRPP	4	31, 36	PC, PE
* 12	EH0119	Seat, Valve, 0.375 FKM	4	31, 36	VC, PC
	EH0125	Seat, Valve, 0.375 EPDM	4	31, 36	VE, PE, VF
* 13	EH0120	Ball, Valve, 0.375 CE	4	31, 36	VC, VE, PC, PE
	E00062	Ball, Valve, 0.375 PTFE	4	31, 36	VF
* 14	EH0121	Gasket, Valve, 0.375 PTFE	2	31, 36	VC, VE, PC, PE, VF
* 15	EH1080	O-Ring, P-3, FKM	1	31, 36	VC, PC
	EH1083	O-Ring, P-3, EPDM	1	31, 36	VE, PE, VF
* 16	EH0029	O-Ring, P-6, FKM	1	31, 36	VC, PC
	EH0052	O-Ring, P-6, EPDM	1	31, 36	VE, PE, VF
* 17	EH0122	O-Ring, P16 FKM	2	31, 36	VC, PC
	EH0127	O-Ring, P16 EPDM	2	31, 36	VE, PE, VF
* 18	EH0027	O-Ring, S-14 FKM	1	31, 36	VC, PC
	EH0050	O-Ring, S-14 EPDM	1	31, 36	VE, PE, VF
19	EH1987	Bolt, M4 x 40 w/PW & SW 316SS	4	B31	all
	EH1986	Bolt, M4 x 35 w/PW & SW 316SS	4	C31	all
	EH1988	Bolt, M5 x 35 w/PW & SW 316SS	4	C36	all
23	EH1079	Knob, Manual Air Vent, PVC	1	31, 36	VC, VE, VF
	EH1089	Knob, Manual Air Vent, GFRPP	1	31, 36	PC, PE
* 27	EH1082	O-Ring, P-11 FKM	1	31, 36	VC, PC
	EH1084	O-Ring, P-11, EPDM	1	31, 36	VE, PE, VF
ZZ	-----	Brass Spacers			Drive specific/Reuse when replacing diaphragm
* 1		Included in spare parts kit			

PVDF Liquid End Exploded View #3 For all PVDF EZ Pump Models

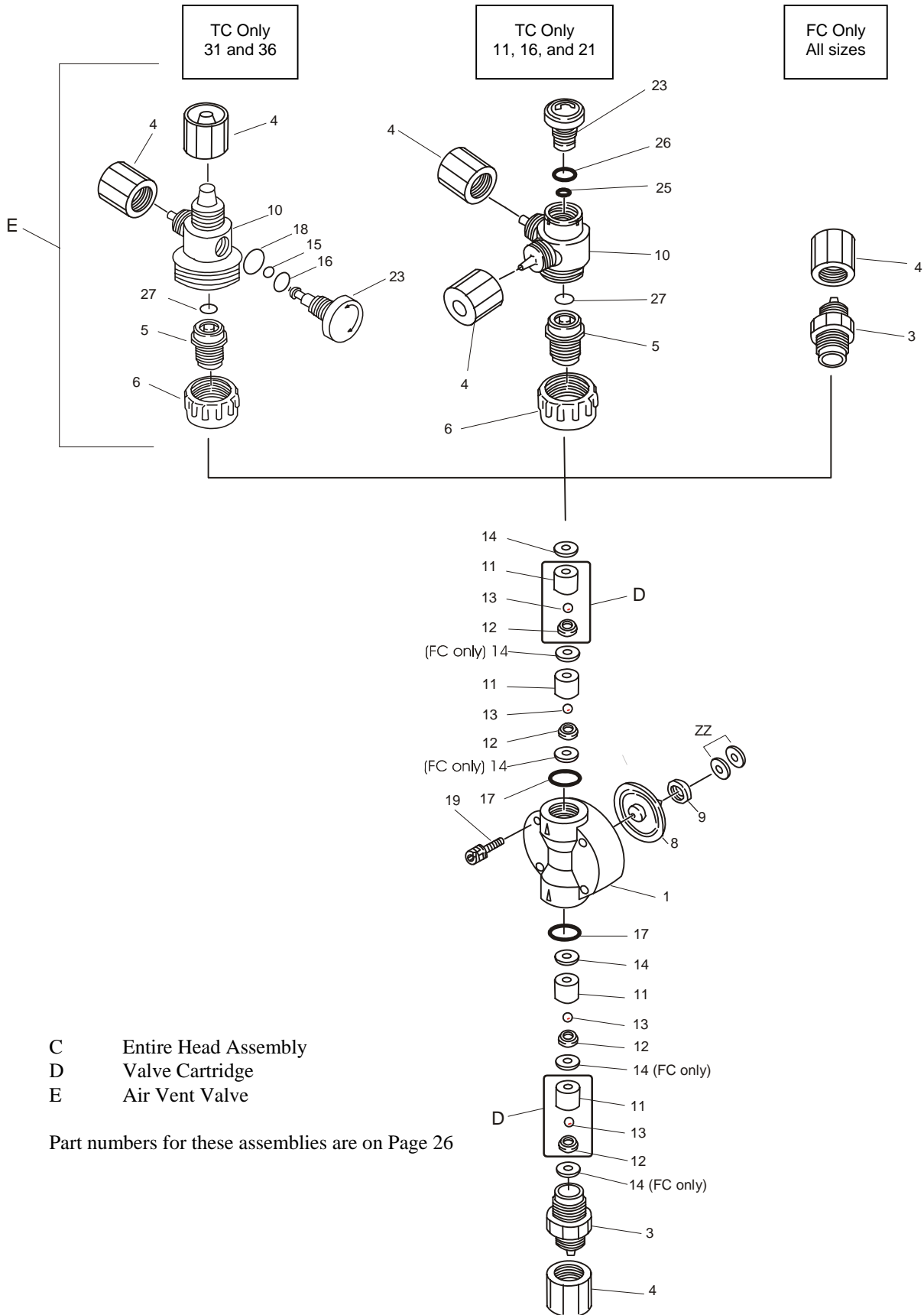

PVDF Liquid End Exploded View #3

Components

Item	Part No	Description	Qty	Size	Liquid End Mtl	
1	EH1963	Head, ZB11, PVDF	1	11	FC, TC	
	EH1968	Head, ZB16, PVDF	1	16	FC, TC	
	EH1964	Head, ZB21, PVDF	1	21	FC, TC	
	EH1969	Head, ZB31, PVDF	1	31	FC, TC	
	EH1970	Head, ZC16, PVDF	1	16	FC, TC	
	EH1965	Head, ZC21, PVDF	1	21	FC, TC	
	EH1966	Head, ZC31, PVDF	1	31	FC, TC	
	EH1967	Head, ZC36, PVDF	1	36	FC, TC	
3	EH0425	Housing, Valve, 3/8 PVDF	2 / 1	11, 16, 21	FC / TC	
	EH0427	Housing, Valve, 1/2 PVDF	2 / 1	31, 36	FC / TC	
4	EH0836	Nut, Coupling, 3/8 PVDF	2 / 3	11, 16, 21	FC / TC	
	EH0837	Nut, Coupling, 1/2 PVDF	2 / 3	31, 36	FC / TC	
5	EH1051	Fitting, Air Vent, PVDF	1	11, 16, 21	TC	
	EH1093	Fitting, Air Vent, PVDF	1	31, 36	TC	
6	EH1047	Nut, Lock, Air Vent, PVDF	1	11, 16, 21	TC	
	EH1092	Nut, Lock, Air Vent, PVDF	1	31, 36	TC	
*	8	EH1971	Diaphragm, Z11	1	11	all
	EH1972	Diaphragm, Z16	1	16	all	
	EH1973	Diaphragm, Z21	1	21	all	
	EH1974	Diaphragm, Z31	1	31	all	
	EH1975	Diaphragm, Z36	1	36	all	
*	9	EH0059	Retainer, Z11	1	11	all
	EH0083	Retainer, Z16	1	16	all	
	EH0067	Retainer, Z21	1	21	all	
	EH0087	Retainer, Z31	1	31	all	
	EH0158	Retainer, Z36	1	36	all	
10	EH1052	Body, Manual Air Vent, PVDF	1	11, 16, 21	TC	
	EH1100	Body, Manual Air Vent, PVDF	1	31, 36	TC	
*	11	EH0340	Guide, Valve, .188 PVDF	4	11	FC
	EH0346	Guide, Valve, .250 PVDF	4	16, 21	FC	
	EH0612	Guide, Valve, .375 PVDF	4	31, 36	FC	
	EH0352	Guide, Valve, .375 PVDF	4	31, 36	FC, TC	
	EH1046	Guide, Valve, .188 PVDF	4	11	TC	
	EH1050	Guide, Valve, .250 PVDF	4	16, 21	TC	
*	12	EH0590	Seat, Valve, .188 PCTFE	4	11	FC
	EH0592	Seat, Valve, .250 PCTFE	4	16, 21	FC	
	EH0593	Seat, Valve, .375 PCTFE	4	31, 36	FC	
	EH0061	Seat, Valve, .188 FKM	4	11	TC	
	EH0069	Seat, Valve, .250 FKM	4	16, 21	TC	
	EH0119	Seat, Valve, .375 FKM	4	31, 36	TC	
*	13	EH0025	Ball, Valve, .188 CE	4	11	FC, TC
	EH0084	Ball, Valve, .250 CE	4	16, 21	FC, TC	
	EH0120	Ball, Valve, .375 CE	4	31, 36	FC, TC	
*	14	EH0342	Gasket, Valve, .188 & .250 PTFE	6 / 2	11, 16, 21	FC / TC
	EH0354	Gasket, Valve, .375, PTFE	6 / 2	31, 36	FC / TC	
15	EH1080	O-Ring, P-3, FKM	1	31, 36	TC	
16	EH0029	O-Ring, P-6, FKM	1	31, 36	TC	
*	17	EH0027	O-Ring, S-14, FKM	2	11, 16, 21	TC
	EH0122	O-Ring, P-16, FKM	2	31, 36	TC	
	EH0591	Gasket, Vhousing, .188/.250 PTFE	2	11, 16, 21	FC	
	EH0355	Gasket, Vhousing, .375 PTFE	2	31, 36	FC	
	EH0613	Gasket, Vhousing, .375 PTFE	2	31, 36	FC	
*	18	EH0027	O-Ring, S-14, FKM	1	31, 36	TC
19	EH1987	Bolt, M4 x 40 w/PW & SW 316SS	4	B11, 16, 21, 31	FC, TC	
	EH1986	Bolt, M4 x 35 w/PW & SW 316SS	4	C16, 21, 31	FC, TC	
	EH1988	Bolt, M5 x 35 w/PW & SW 316SS	4	C36	FC, TC	
23	EH1049	Knob, Air Vent Valve	1	11, 16, 21	FC, TC	
	EH1094	Knob, Air Vent, 1/2, PVDF	1	31, 36	FC, TC	
*	25	EH0300	O-Ring, P-4, FKM	1	11, 16, 21	TC
*	26	EH0302	O-Ring, P-10A, FKM	1	11, 16, 21	TC
*	27	EH0304	O-Ring, P-7, FKM	1	11, 16, 21	TC
	EH1082	O-Ring, P-11, FKM	1	31, 36	TC	
ZZ	-----	Brass spacers		Drive specific/Re-use when replacing diaphragm		

* Included in spare parts kit

Accessories (Not Shown)

Part No.	Description	Size	Liquid End Mtl
E90001	Valve, Injection 3/8	11, 16, 21	VC
E90002	Valve, Injection 3/8	11, 16, 21	VE, VF
E90003	Valve, Injection, 3/8	11, 16, 21	PC
E90004	Valve, Injection, 3/8	11, 16, 21	PE
E90007	Valve, Injection, 1/2	31, 36	VC
E90008	Valve, Injection, 1/2	31, 36	VE, VF
E90011	Valve, Injection, 1/2	31, 36	PC
E90012	Valve, Injection, 1/2	31, 36	PE
E90238	Valve, Injection, 3/8	11, 16, 21	TC
E90020	Valve, Inj/Back Press, 3/8	11, 16, 21	FC
E90022	Valve, Inj/Back Press, 1/2	31, 35	TC, FC
E90013	Valve, Foot, 3/8	11, 16, 21	VC
E90015	Valve, Foot, 3/8	11, 16, 21	PC
E90016	Valve, Foot, 1/2	31, 36	VC
E90018	Valve, Foot, 1/2	31, 36	PC
E90034	Valve, Foot, 3/8	11, 16, 21	PE
E90035	Valve, Foot, 3/8	11, 16, 21	VE
E90036	Valve, Foot, 1/2	31, 36	PE
E90037	Valve, Foot, 1/2	31, 36	VE
E90193	Valve, Foot, 1/2	31, 36	VF
E90234	Valve, Foot, 3/8	11, 16, 21	VF
E90239	Valve, Foot, 1/2	31, 36	TC
E90240	Valve, Foot, 3/8	11, 16, 21	TC
E90241	Valve, Foot, 3/8	11, 16, 21	FC
E90275	Valve, Foot, 1/2	31, 36	FC
E00001-00	Tubing, 1/2 OD LLDPE per foot	31, 36	all
E00001	Tubing, 1/2 OD LLDPE, 20 FT	31, 36	all
E00001-50	Tubing, 1/2 OD LLDPE, 50 FT	31, 36	all
E00001-100	Tubing, 1/2 OD LLDPE, 100 FT	31, 36	all
E00001-250	Tubing, 1/2 OD LLDPE, 250 FT	31, 36	all
E00001-500	Tubing, 1/2 OD LLDPE, 500 FT	31, 36	all
E00002-00	Tubing, 3/8 OD LLDPE per foot	11, 16, 21	all
E00002	Tubing, 3/8 OD LLDPE, 20 FT	11, 16, 21	all
E00002-50	Tubing, 3/8 OD LLDPE, 50 FT	11, 16, 21	all
E00002-100	Tubing, 3/8 OD LLDPE, 100 FT	11, 16, 21	all
E00002-250	Tubing, 3/8 OD LLDPE, 250 FT	11, 16, 21	all
E00002-500	Tubing, 3/8 OD LLDPE, 500 FT	11, 16, 21	all
E00071	Weight, Ceramic	all	all

Drive and Control Module Exploded View

B: D-CONTROL MODULE

T-CONTROL MODULE

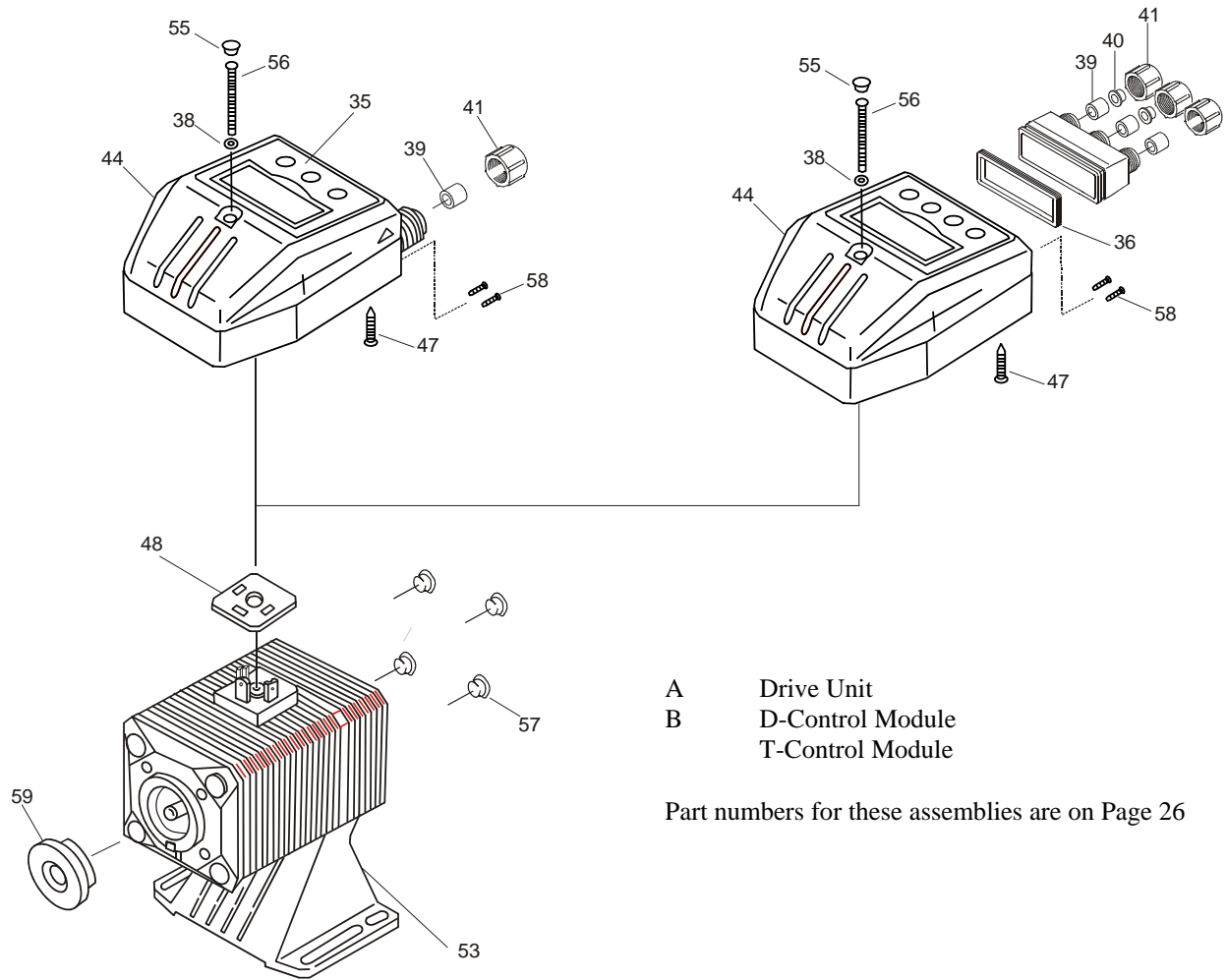

- A Drive Unit
- B D-Control Module
- T-Control Module

Part numbers for these assemblies are on Page 26

A: DRIVE UNIT

Item	Part No.	Description	Series
35	E00152	Cover, Keypad	EZ-D
	E00153	Membrane Keypad	EZ-D
36	EH1036	Gasket, Terminal Box	EZ-T
38	EH0261	Gasket, M3 x 35 Bolt	EZ-D, EZ-T
39	EH0202	Grommet, Cord	EZ-D, EZ-T
40	EH0204	Cap, Strain Relief	EZ-D, EZ-T
41	EH0205	Nut, Strain Relief	EZ-D, EZ-T
47	EH0269	Screw, Control Module	EZ-D, EZ-T
48	EH0547	Gasket, Terminal Block	EZ-D, EZ-T
53	1110027300	Base, EZ-C, Blue	EZC
	1120357900	Base, EZ-B, Blue	EZB
55	EH0289	Plug, Control Module	EZ-D, EZ-T
56	EH0241	Screw, M3 x 35 SS PH	EZ-D, EZ-T
57	EH0549	Plug, Bolt	EZ-D, EZ-T
58	EH1438	Screw, Self Tap, D-module	EZ-D, EZ-T
59	EH1690	Spacer, Bracket, EZ-11	EZ-D, EZ-T
	EH1431	Spacer, Bracket, EZ-16	EZ-D, EZ-T
	EH1700	Spacer, Bracket, EZ-21	EZ-D, EZ-T
	EH1702	Spacer, Bracket, EZ-31	EZ-D, EZ-T
	EH1714	Spacer, Bracket, EZ-16	EZ-D

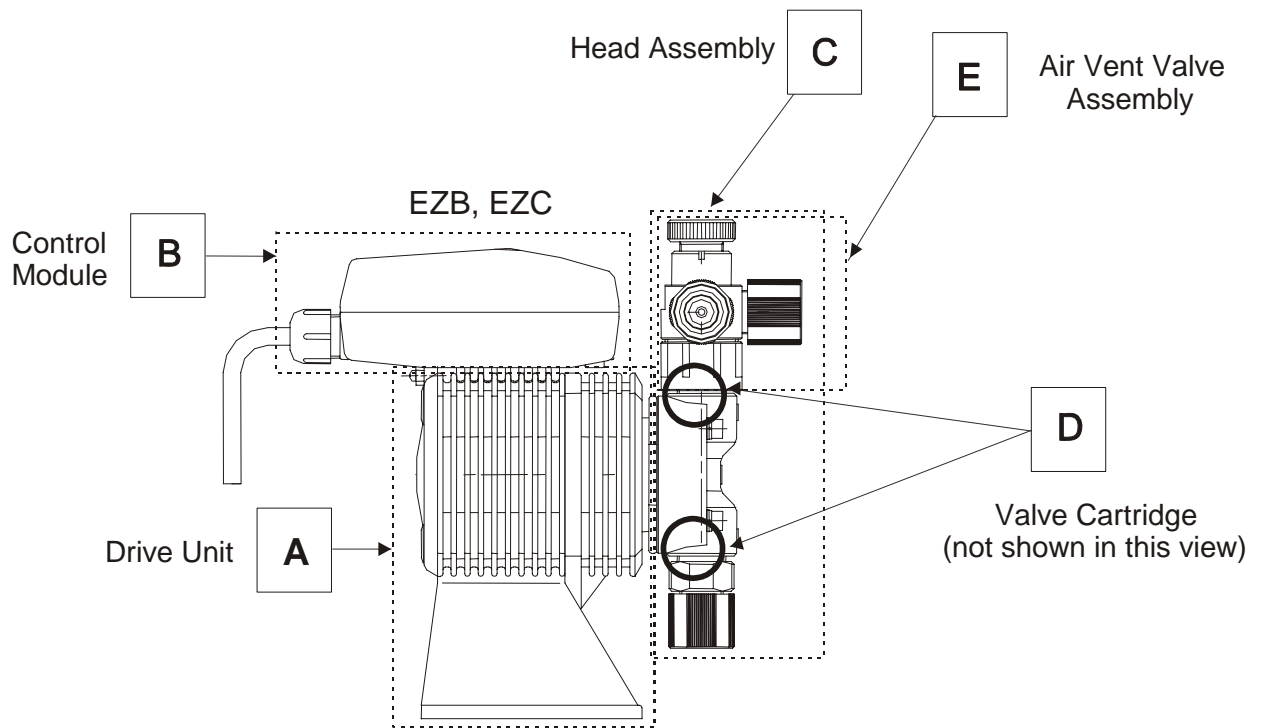

Key letters:

A	Drive Unit
B	Control Module
C	Head Assembly

D	Valve Cartridge
E	Air Vent Valve Assembly

Pump Model [†]	A Drive Unit [†]	B Control Module [†]	C Head Assembly * (Spare Parts Kit)						
			PC	PE	VC	VE	VF	TC	FC
EZB11D1-	ZB11-D1	EZBD1	ZB11PC (X11PC-PK)	ZB11PE (X11PE-PK)	ZB11VC (X11VC-PK)	ZB11VE (X11VE-PK)	ZB11VF (X11VF-PK)	ZB11TC (Z11TC-PK)	ZB11FC (Z11FC-PK)
EZB11D2-	ZB11-D2	EZBD2							
EZB16D1-	ZB16-D1	EZBD1	ZB16PC (X16PC-PK)	ZB16PE (X16PE-PK)	ZB16VC (X16VC-PK)	ZB16VE (X16VE-PK)	ZB16VF (X16VF-PK)	ZB16TC (Z16TC-PK)	ZB16FC (Z16FC-PK)
EZB16D2-	ZB16-D2	EZBD2							
EZB21D1-	ZB21-D1	EZBD1	ZB21PC (X21PC-PK)	ZB21PE (X21PE-PK)	ZB21VC (X21VC-PK)	ZB21VE (X21VE-PK)	ZB21VF (X21VF-PK)	ZB21TC (Z21TC-PK)	ZB21FC (Z21FC-PK)
EZB21D2-	ZB21-D2	EZBD2							
EZB31D1-	ZB31-D1	EZBD1	ZB31PC (X31PC-PK)	ZB31PE (X31PE-PK)	ZB31VC (X31VC-PK)	ZB31VE (X31VE-PK)	ZB31VF (X31VF-PK)	ZB31TC (Z31TC-PK)	ZB31FC (Z31FC-PK)
EZB31D2-	ZB31-D2	EZBD2							
EZC16D1-	ZC16-D1	EZCD1	X16PC (X16PC-PK)	X16PE (X16PE-PK)	X16VC (X16VC-PK)	X16VE (X16VE-PK)	X16VF (X16VF-PK)	ZC16TC (Z16TC-PK)	ZC16FC (Z16FC-PK)
EZC16D2-	ZC16-D2	EZCD2							
EZC21D1-	ZC21-D1	EZCD1	X21PC (X21PC-PK)	X21PE (X21PE-PK)	X21VC (X21VC-PK)	X21VE (X21VE-PK)	X21VF (X21VF-PK)	ZC21TC (Z21TC-PK)	ZC21FC (Z21FC-PK)
EZC21D2-	ZC21-D2	EZCD2							
EZC31D1-	ZC31-D1	EZCD1	X31PC (X31PC-PK)	X31PE (X31PE-PK)	X31VC (X31VC-PK)	X31VE (X31VE-PK)	X31VF (X31VF-PK)	ZC31TC (Z31TC-PK)	ZC31FC (Z31FC-PK)
EZC31D2-	ZC31-D2	EZCD2							
EZC36D1-	ZC36-D1	EZCD1	X36PC (X36PC-PK)	X36PE (X36PE-PK)	X36VC (X36VC-PK)	X36VE (X36VE-PK)	X36VF (X36VF-PK)	ZC36TC (Z36TC-PK)	ZC36FC (Z36FC-PK)
EZC36D2-	ZC36-D2	EZCD2							
D Valve Cartridge EZ	11	E90041	E90042	E90038	E90039	E90302	E90305	E90044	
	16, 21	E90048	E90049	E90045	E90046	E90303	E90306	E90051	
	31, 36	E90055	E90056	E90052	E90053	E90304	E90309	E90441	
E Manual Air Vent Valve Assembly	11, 16, 21	E90026	E90027	E90024	E90025	E90025	E90308	---	
	31, 36	E90248	E90249	E90246	E90247	E90247	E90250	---	
Automatic Air Vent Valve	11, 16, 21	---	---	E90023	---	---	---	---	
MultiFunction Valve Assembly	11, 16, 21	E90364	E90365	E90362	E90363	E90363	---	---	

Notes:

* The P/N in the block is the head assembly part number and the spare parts kit is shown underneath in parentheses. For head assemblies with a Multifunction Valve, add an "M" to the end of the part number. Parts kits for pumps with Multifunction valves are the same as pumps without the "M" option.

† For pump models using a "T" Control Module, change the "D" in the model number or part number to a "T" to determine the correct Control Module part number.

6.0 TROUBLESHOOTING



CAUTION: Before working on the pump, disconnect the power cord, depressurize the discharge tubing and drain or flush any residual liquid from the pump head and valves, using proper chemical handling techniques.

Problem	Possible Cause	Corrective Action
<i>Pump does not start</i>	Faulty wiring	Correct wiring
	Improper voltage	Connect to proper voltage source
	Electronic control unit is damaged	Replace control unit
<i>Pump does not prime</i>	Air in suction tubing	Reroute suction tubing to eliminate air trap
	Valve gasket is not installed	Install valve gasket
	Valve set assembly direction is wrong.	Reassemble valve set
	Pump is air locked	Open air vent valve
	Suction or discharge valve is clogged with foreign matter	Disassemble, inspect, clean
	Ball stuck to valve seat	Disassemble, inspect, clean
<i>Output fluctuates</i>	Suction or discharge valve is clogged with foreign matter	Disassemble, inspect, clean
	Air is trapped in pump	Open air vent valve
	Overfeeding	Install injection valve or back pressure valve
	Diaphragm is damaged	Replace diaphragm
<i>Liquid leaks</i>	Fitting or coupling nut is loose	Re-install (see section 2.3/2.4)
	Pump head is loose	Tighten pump head bolts Torque: 19 lb-in (2.16 N-m)
	Diaphragm is damaged	Replace diaphragm
	O-ring or valve gasket missing	Install o-ring or valve gasket

7.0 SERVICE POLICY

The EZ Series electronic metering pumps have a 2-year warranty. Contact your Walchem distributor for service.

Five Boynton Road Hopping Brook Park Holliston, MA 01746 USA TEL 508-429-1110 FAX 508-429-7433
WEBSITE: www.walchem.com