



2" PW Series

SPECIALTY PUMP

ARO® PW20P-YPX-XXX EXP Pumps

- Upgrade to EXP from existing Wilden® P800 or PS800 pumps, or Versa-Matic® U2 pumps.
- ARO® pump matches the fluid inlet/outlet port dimensions of the pumps and it matches Wilden's mounting feet location.
- Leave the stalling issues and complex maintenance procedures behind.
- ARO® has the lowest total cost of ownership over the competition.

Ratio:	1:1
Maximum GPM (LPM):	184 (696)
Displacement per cycle Gallons (Liters):	1.4 (5.3)
Air Inlet (Female):	3/4 - 14 N.P.T.
Fluid Inlet/Outlet:	2" ANSI/DIN hybrid flange (center)
Max. operating pressure psi (bar):	120 (8.3)
Suspended solids max. dia. in. (mm):	1/4" (6.4)
Weight lbs (kg):	Polypropylene 89.0 (40.4) PVDF 116.8 (53)
Maximum dry suction lift ft (m):	19.5 (5.9)
Sound Level:	70 PSI 60 Cycles / Min 85.0 db(A)



Ordering

Position	1	2		3	4	5		6	7	8
Example:	PW20	P	-	Y	P	S	-	X	X	X

Position 1 Model Series	Position 2 Center Section	Position 3 Connection	Position 4 Wetted Parts	Position 5 Hardware	Position 6 Seat Material	Position 7 Ball Material	Position 8 Diaphragm Material
PW20 - Standard Pump	P - Polypropylene	Y - 2" ANSI/DIN Hybrid Center Flange	K - PVDF P - Polypropylene	S - Stainless Steel	K - PVDF P - Polypropylene	A - Santoprene® C - Hytrel® G - Nitrile T - PTFE V - Viton®	A - Santoprene® C - Hytrel® G - Nitrile L - Long Life PTFE T - PTFE/ Santoprene® V - Viton®

Hytrel® is a registered trademark of DuPont company, Santoprene® is registered trademark of Monsanto, Viton® is a registered trademark of ExxonMobil, VERSA-MATIC® is a registered trademark of Versa-Matic Pump Company (IDEX Corp) and Wilden® is a registered trade name of Wilden Pump and Engineering Company, a Dover Resources Company.

Accessories

Service Repair Kits | 637369 (air motor),
637373-XXX (fluid section with seats),
637374-X (major air valve assembly)

Continuous-Duty Muffler | 67323 Recommended for continuous-duty and high-flow applications. Muffler features large expansion chamber, permitting cold exhaust air to exit pump

Flange Connection Kit | 67341-E20N

Diaphragm Failure Detection | Kit No.67237

Air Line Connection Kit | 66109 (Piggyback Filter/Regulator with gauge, pipe nipple and 5-foot air hose)



Dimensions and performance curves on the reverse side.



2" PW Series Dimensions and Flow Charts

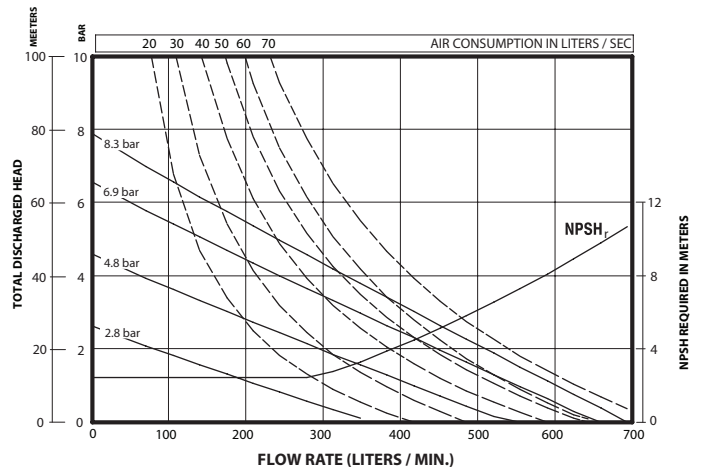
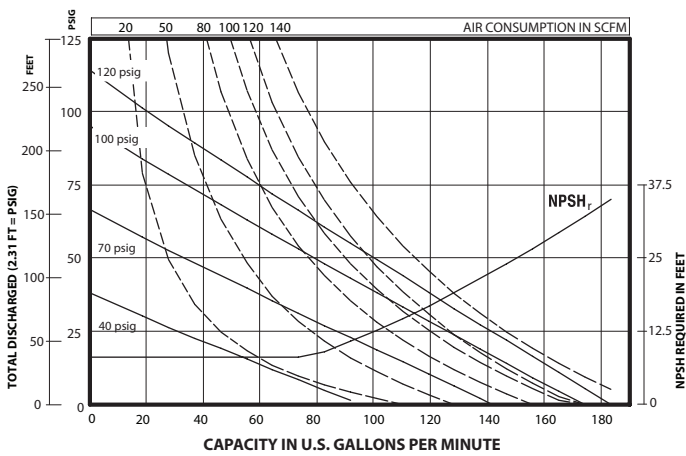
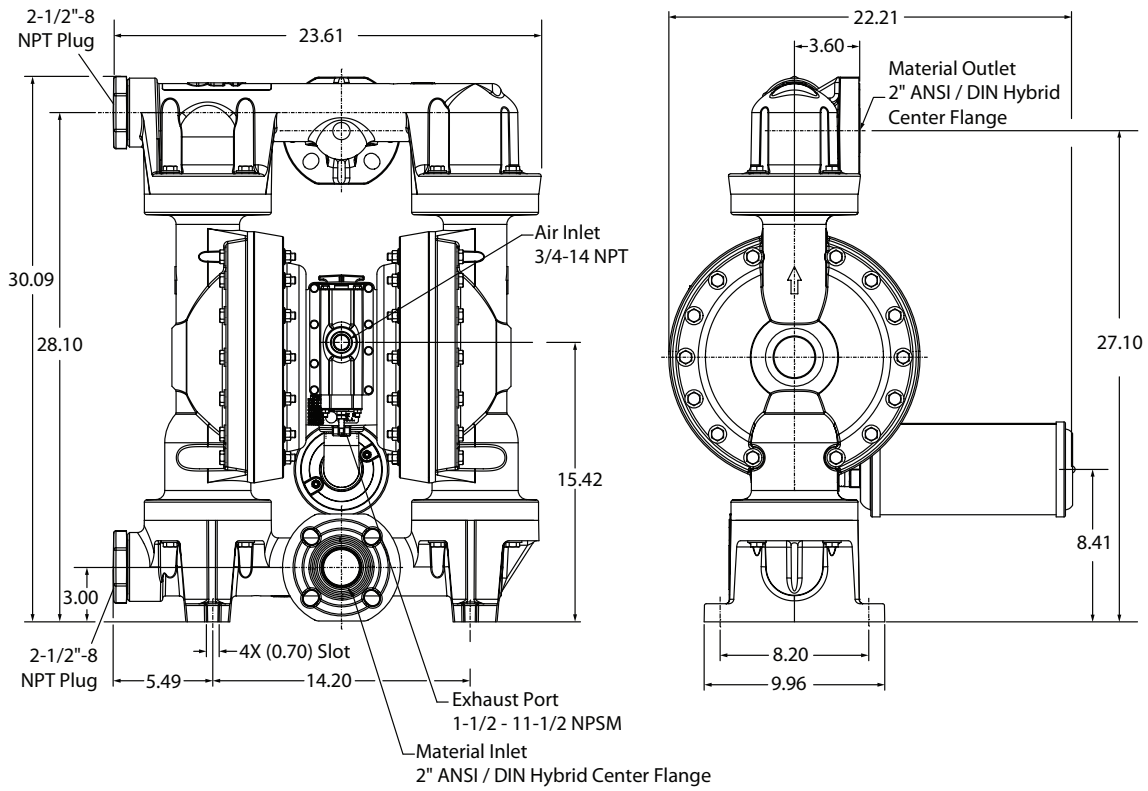

Performance based on an elastomeric fitted pump (PW20P-YPS-XXX), flooded suction with water at ambient conditions.
 Due to varying materials of construction, assembly configurations and operating conditions, published data is for reference only