

WELCOME TO THE "REVOLUTION"

NEW

CPVC body provides higher temperature ratings and better chemical resistance capabilities than PVC Dampeners



"Revolutionary" Pulsation Dampener features:

1. **NEW CPVC body with temperature ratings up to 180°F & a variety of chemically resistant bladder materials to provide complete chemical compatibility**
2. **Threaded housings instead of metal fasteners to reduce damage common in corrosive environments.**

PVC Bladders - A Blacoh Exclusive!



NEW CPVC
Body Construction

USE A PULSATION DAMPENER TO:

- Reduce pump pulsation, pipe vibration, and shaking up to 99%
- Protect plastic piping, joints, and fittings from breaking or leaking
- Extend pump component life and improve pump performance
- Minimize pump cavitation
- Limit damaging pressure surges caused by pump start-up and shut-down
- Remove tube motion that abrades and shortens tube life
- Eradicate splashing, foaming, or product degradation
- Ensure accurate reading of flow meters and gauges
- Produce a smooth and even flow for spraying or filling

(800) 603-7867
www.Blacoh.com

BLACOH
FLUID CONTROL

Member of
Hydraulic



SENTRY
PULSATION DAMPENERS

SENTINEL
DIAPHRAGM SEALS

SPILL STOP
LEAK CONTAINMENT



"REVOLUTION" 10 CUBIC INCH (.16L) CPVC PULSATION DAMPENER

Chargeable

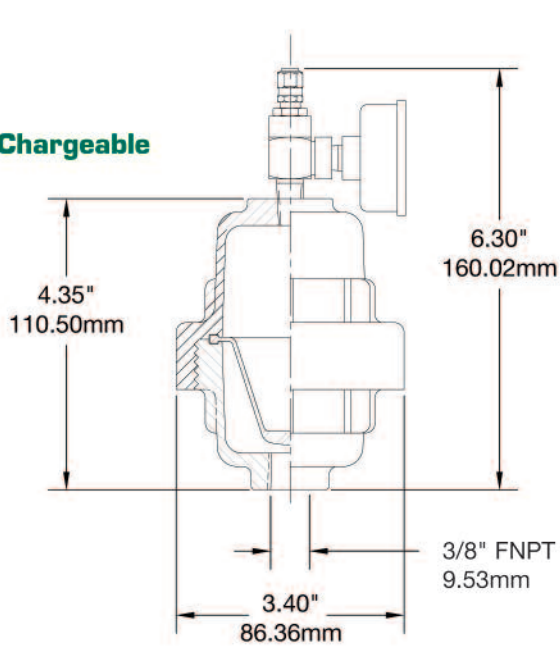

Adjustable

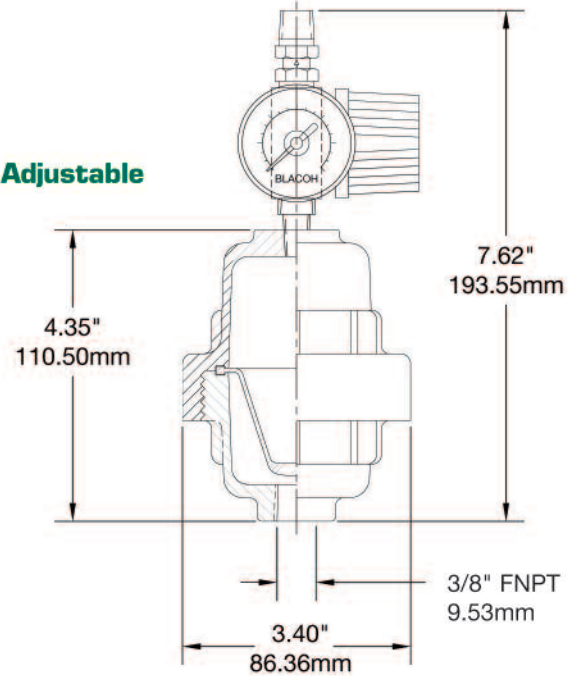

Inlet Stabilizer

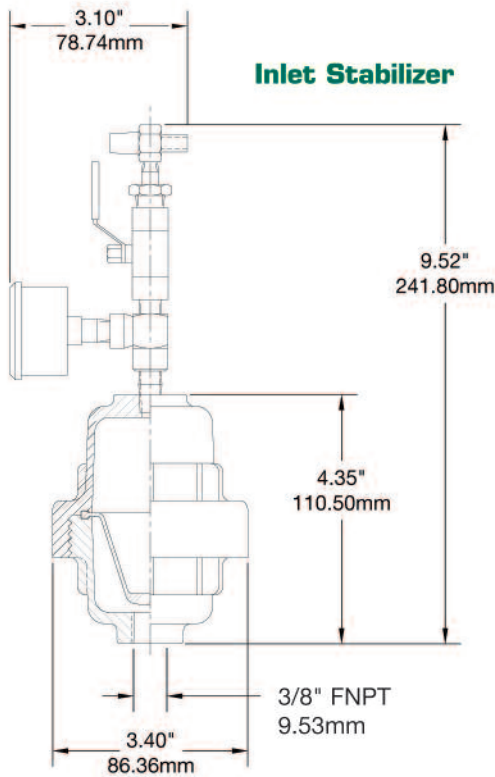

UNITS WITH 1/2" (12.7MM) FNPT INLET

| AIR CONTROL BLADDER | CHARGEABLE MODEL | ADJUSTABLE MODEL | INLET STABILIZER MODEL |
|-------------------------|---------------------|---------------------|---------------------------|
| PVC | RC-10X-X50 | RM-10X-X50 | RJ-10X-X50 |
| SANTOPRENE | RC-10X-W50 | RM-10X-W50 | RJ-10X-W50 |
| NEOPRENE | RC-10X-N50 | RM-10X-N50 | RJ-10X-N50 |
| BUNA | RC-10X-B50 | RM-10X-B50 | RJ-10X-B50 |
| EPDM | RC-10X-E50 | RM-10X-E50 | RJ-10X-E50 |
| HYPALON | RC-10X-H50 | RM-10X-H50 | RJ-10X-H50 |
| SILICONE- FOOD GRADE | RC-10X-S50 | RM-10X-S50 | RJ-10X-S50 |
| VITON | RC-10X-V50 | RM-10X-V50 | RJ-10X-V50 |
| AFLAS | RC-10X-A50 | RM-10X-A50 | RJ-10X-A50 |
| PTFE | RC-10X-T50 | RM-10X-T50 | RJ-10X-T50 |

For 3/8" (9.53mm) FNPT Inlet - Last two digits of model number change to 38.

Please call your local distributor:



Call for your **FREE**
Demonstration CD

BLACOH
FLUID CONTROL

601 Columbia Ave, Bldg. D, Riverside, CA 92507 • USA
Tel: (800) 603-7867 or (951) 342-3100 • Fax: (951) 342-3101
E-mail: sales@blacoh.com • Website: www.blacoh.com