

# OPERATOR'S MANUAL AND SALES AND ENGINEERING DATA

INCLUDING: SPECIFICATIONS, SERVICE KITS, GENERAL INFORMATION, PARTS, TROUBLESHOOTING. RELEASED: 9-15-10  
 INCLUDE MANUALS: AF04XX-XX Air Motor (pn 97999-1466) & S-632 General Information Manual (pn 97999-624). (REV. 01)

**4-1/4" AIR MOTOR**  
**9:1 RATIO**  
**4" STROKE**

## AF0409AX3XXXX-XX-X Basic Oil Pump



**READ THIS MANUAL CAREFULLY BEFORE INSTALLING,  
 OPERATING OR SERVICING THIS EQUIPMENT.**

It is the responsibility of the employer to place this information in the hands of the operator. Keep for future reference.  
 The original language of this manual is English.

### SERVICE KITS

- Use only genuine ARO® replacement parts to assure compatible pressure rating and longest service life.
- **637489** for repair of AF044X-XX air motor.
- **637486** for lower end pump.
- **65823** packing kit assembly.

### SPECIFICATIONS

<b>Model Series</b> (refer to option chart)	AF0409AX3XXXX-XX-X
<b>Pump Type</b>	Air Operated, Two-Ball Pump
<b>Drum Size</b>	models AF0409AX3P31 .... Remote Mounting
	models AF0409AX3P34 .... 16 gallon
	models AF0409AX3P35 .... 55 gallon
<b>Ratio</b>	9:1
<b>Air Motor</b>	AF044X-XX
<b>Motor Repair Kit</b>	637489
<b>Motor Diameter</b>	4-1/4" (10.8 cm)
<b>Stroke (double acting)</b>	4" (10.2 cm)
<b>Air Inlet (female)</b>	1/2 - 14 NPTF - 1
<b>Air Exhaust (female)</b>	1-1/4 - 11-1/2 NPTF - 1
<b>Material Outlet (female)</b>	3/4 - 14 NPTF
<b>Lower End Pump</b>	
models AF0409A13XXXX	60873
models AF0409A43XXXX	65033-1
models AF0409A53XXXX	65033
<b>Dimensional Data</b>	see figure 1

### PUMP PERFORMANCE

<b>Air Inlet Pressure Range</b>	0 - 150 p.s.i.g. (0 - 10.3 bar)
<b>Fluid Pressure Range</b>	0 - 1350 p.s.i.g. (0 - 93.1 bar)
<b>Maximum Rec'd Cycles / Minute</b>	75
<b>Displacement In.<sup>3</sup> Per Cycle</b>	12.0
<b>Volume / Cycle</b>	6.65 oz. (196.8 ml)
<b>Cycles Per Gallon</b>	19.2
<b>Maximum Working Flow Rate</b>	3.9 g.p.m. (14.8 l.p.m.)
<b>Noise Level @ 60 p.s.i. - 40 c.p.m.</b> ①	81.8 db(A)②

① The pump sound pressure level has been updated to an Equivalent Continuous Sound Level (LAeq) to meet the intent of ANSI S1.13-1971, CAGI-PNEUROPS S5.1 using four microphone locations.

### GENERAL DESCRIPTION

The 9:1 ratio is an expression of the relationship between the effective air motor area and the effective lower pump area. When 150 p.s.i. (10.3 bar) of air pressure is supplied to the air motor, the lower pump end will develop a maximum 1350 p.s.i. (93.1 bar) of fluid pressure (at no flow). As the fluid control is opened, the flow rate will increase as the air motor cycle rate increases to keep up with demand.

### PUMP DATA

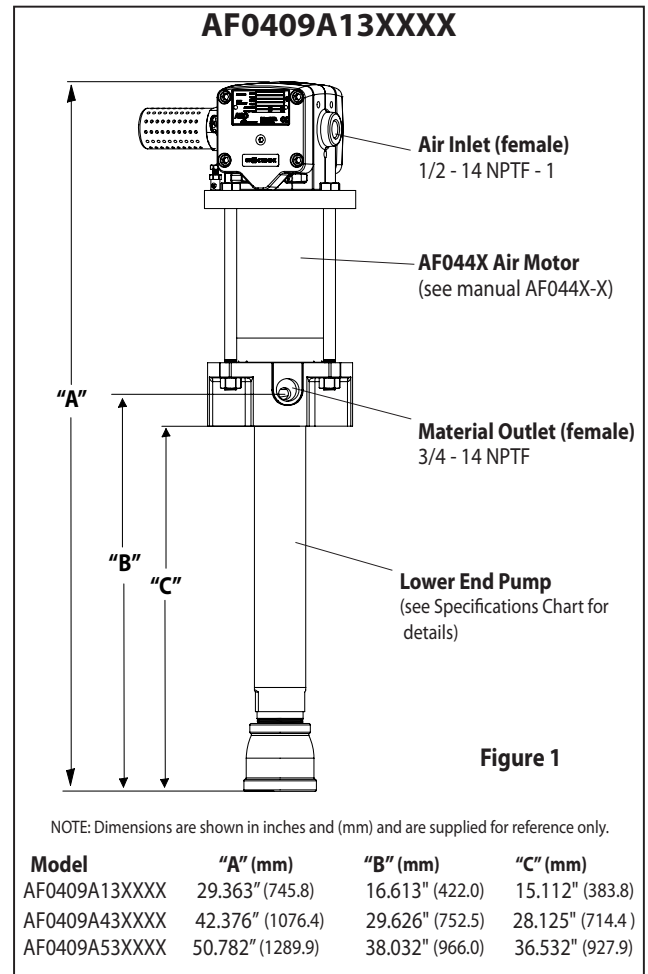

### IMPORTANT

**This is one of five documents which support the pump. Replacement copies of these forms are available upon request.**

- AF0409AX3XXXX** Model Operator's Manual (pn 97999-1490)
- S-632** General Information - Air / Hydraulic Operated Piston Pumps (pn 97999-624)
- 60873** Lower End Pump Manual
- 65033** Lower End Pump Manual
- AF04XX-XX** Air Motor Operator's Manual (pn 97999-1466)

## MODEL DESCRIPTION CHART

AF0409 A X 3 X X X X-X X

**Check Type / Wetted Material**

A - Two Ball, Carbon Steel

**Container Suitability**

1 - Remote Mounting  
4 - 16 Gallon (120 lbs)  
5 - 55 gallon (400 lbs)

**Inlet / Outlet Thread Type**

3 - Fluid Outlet

**Upper Packing**

P - Polyurethane

**Lower Packing**

F - UHMW-PE

**Spring Type / Solvent Cup**

L - Coil Spring, No Solvent Cup

**Plunger Type**

1 - Carbon Steel

**Air Motor Option**

Blank - No Option  
0 - No Option  
1 - Integrated Ball Valve Regulator

**Pump Option**

Blank - No Option

## OPERATING AND SAFETY PRECAUTIONS

**⚠ WARNING HAZARDOUS PRESSURE. Do not exceed maximum operating pressure of 1350 p.s.i. (93.1 bar) at 150 p.s.i. (10.3 bar) inlet air pressure.**

<b>Pump Ratio X Inlet Pressure to Pump Motor</b>	<b>=</b>	<b>Maximum Pump Fluid Pressure</b>
Pump ratio is an expression of the relationship between the pump motor area and the lower pump end area. EXAMPLE: When 150 p.s.i. (10.3 bar) inlet pressure is supplied to the motor of a 4:1 ratio pump, it will develop a maximum of 600 p.s.i. (41.4 bar) fluid pressure (at no flow) - as the fluid control is opened, the flow rate will increase as the motor cycle rate increases to keep up with the demand.		

**⚠ WARNING Refer to general information sheet for additional safety precautions and important information.**

- The two-ball pumps are primarily designed for the pumping of medium viscosity fluids. The two-ball design provides better priming of the lower foot valve. The double acting feature is standard in all ARO industrial pumps. Material is delivered to the pump discharge outlet on both the up and down stroke.

NOTICE: Thermal expansion can occur when the fluid in the material lines is exposed to elevated temperatures. Example: Material lines located in a non-insulated roof area can warm due to sunlight. Install a pressure relief valve in the pumping system.

**Replacement warning label (pn 92325) is available upon request.**

### PUMP CONNECTION - UPPER / LOWER

**NOTE: All threads are right hand.**

- Unscrew the lower pump assembly from the air motor.
- Pull the air motor from the lower pump end until motor piston rod is in the "down" position and lower pump end rod is in "up" position.
- Using e-ring pliers, slide the retaining ring up far enough to allow the sleeve to move upward and release the two connectors.

#### REASSEMBLY

- Align the pump motor with the lower pump end.

- Install the two connectors and retain with the sleeve, slide the retaining ring back into position.
- Screw the lower pump assembly to the air motor. NOTE: Tighten tube to 90 - 100 ft lbs (122.0 - 135.6 Nm).

### LOWER PUMP END DISASSEMBLY

NOTE: All threads are right hand.

- While holding tube securely with a strap wrench, unthread and remove foot valve seat.
- Remove ball stop pin, releasing ball.
- Push piston rod and components out thru the bottom of tube.
- Unthread and remove inner check seat, releasing washer, cup and ball.
- Loosen nut to unthread and remove cup follower from piston rod.

### LOWER PUMP END ASSEMBLY

**NOTE: Thoroughly clean and lubricate all seals. Replace all soft parts with new ones included in the repair kit.**

- Assemble adapter to piston rod. NOTE: Apply Loctite® 242® to threads of piston rod before assembly.
- Assemble nut and cup follower to piston rod, tightening nut against cup follower. NOTE: Tighten nut to 60 - 70 ft lbs (81.3 - 94.9 Nm).
- Assemble cup, washer and ball to cup follower, securing with inner check seat. NOTE: Tighten inner check seat to 65 - 70 ft lbs (88.1 - 94.9 Nm).
- Assemble "O" ring, ball and ball stop pin to foot valve seat. NOTE: Assemble pin to farthest hole from ball.
- Assemble foot valve seat and components to tube. NOTE: Tighten foot valve seat to 125 - 150 ft lbs (169.5 - 203.4 Nm).

## DIMENSIONS

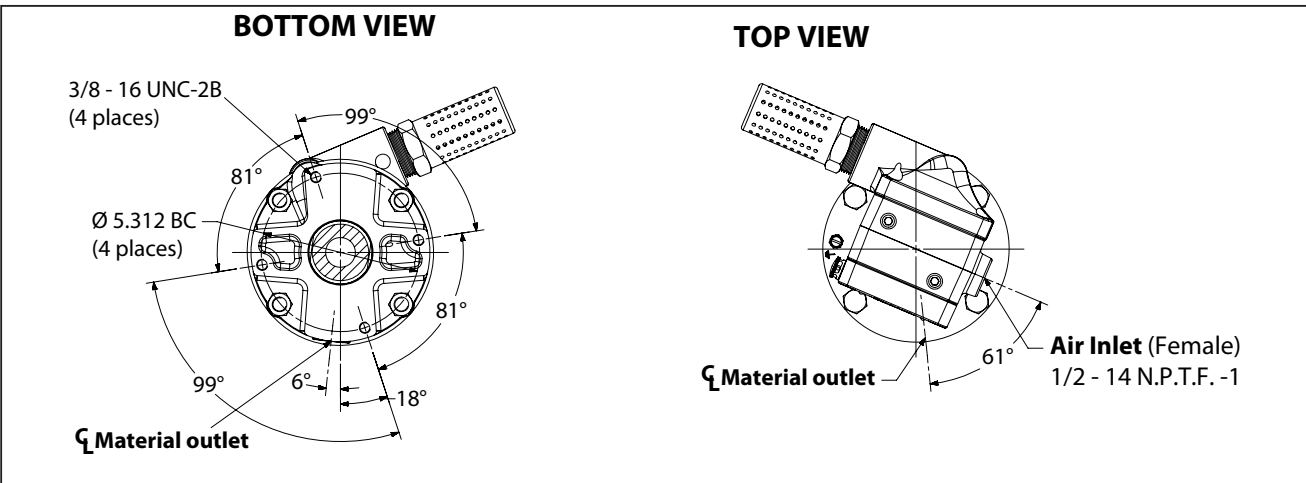

# PERFORMANCE CURVES

