

TROUBLESHOOTING

Product discharged from exhaust outlet.

- Check for diaphragm rupture.
- Check tightness of (14) diaphragm screw.

Air bubbles in product discharge.

- Check connections of suction plumbing.
- Check "O" rings between intake manifold and fluid caps.
- Check tightness of (14) diaphragm screw.

Low output volume, erratic flow or no flow.

- Check air supply.
- Check for plugged outlet hose.

- Check for kinked (restrictive) outlet material hose.
- Check for kinked (restrictive) or collapsed inlet material hose.
- Check for pump cavitation - suction pipe should be sized at least as large as the inlet thread diameter of the pump for proper flow if high viscosity fluids are being pumped. Suction hose must be a non-collapsing type, capable of pulling a high volume.
- Check all joints on the inlet manifolds and suction connections. These must be air tight.
- Inspect the pump for solid objects lodged in the diaphragm chamber or the seat area.

DIMENSIONAL DATA

Dimensions shown are for reference only, they are displayed in inches and millimeters (mm).

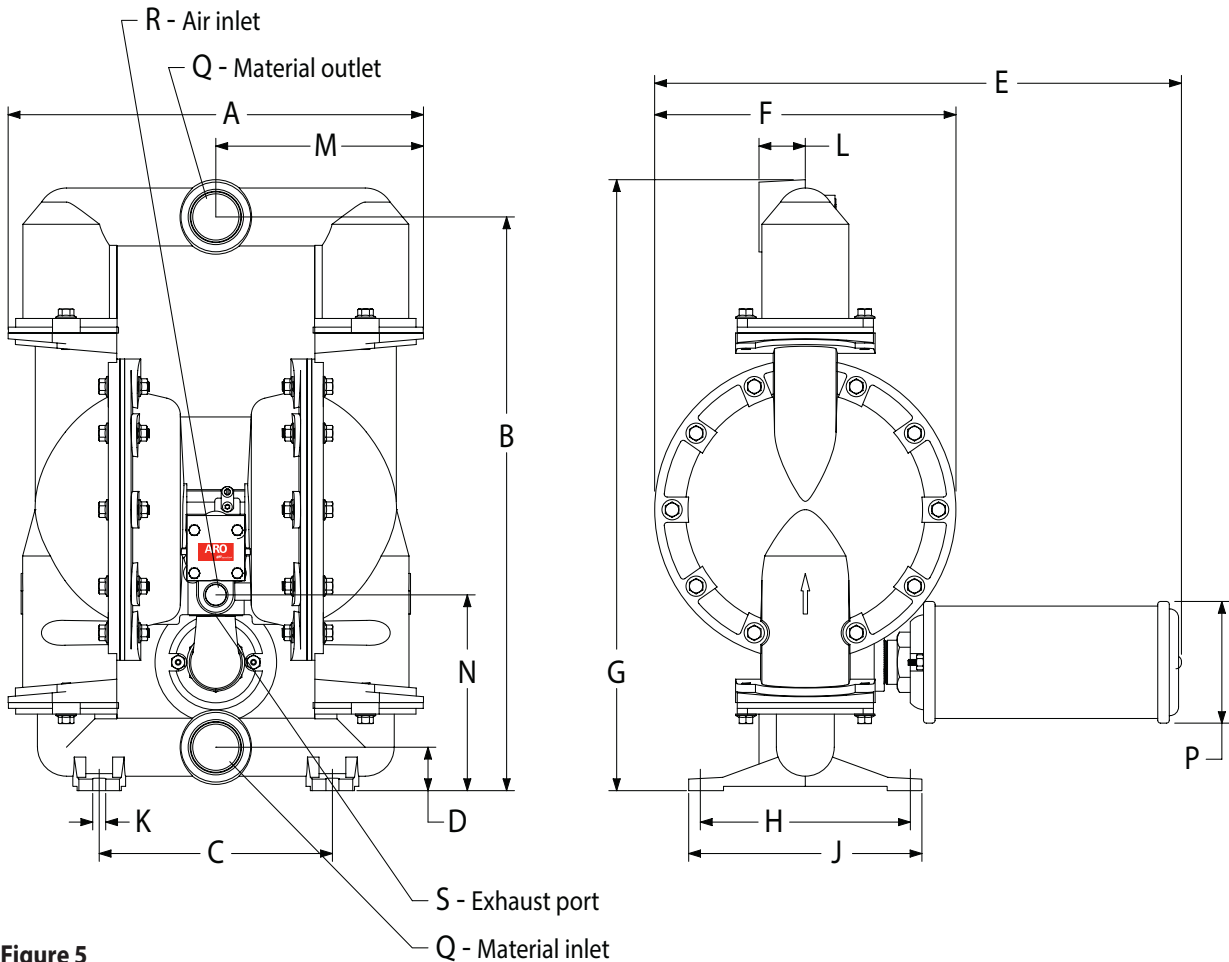

Figure 5

DIMENSIONS

A - see below	F - 13" (330.2 mm)	K - 9/16" (14.3 mm)	P - 5-1/4" (133.4 mm)
B - 24-3/4" (628.7 mm)	G - see below	L - see below	Q - see below
C - 10-1/16" (255.6 mm)	H - 9-1/16" (230.2 mm)	M - see below	R - 3/4 - 14 NPTF - 2
D - 1-7/8" (47.6 mm)	J - 10-1/16" (255.6 mm)	N - 8-15/32" (214.6 mm)	S - 1-1/4 - 11-1/2 NPTF - 2
E - 22-3/4" (577.7 mm)			

Model	"A"	"G"	"L"	"M"	Model	"Q"
6662X0-XXX-C	17-15/16" (455.1 mm)	26-3/8" (669 mm)	2" (50.8 mm)	8-31/32" (227.6 mm)	666250-XXX-C	2 - 11-1/2 NPTF - 2
6662X1-XXX-C	17-29/32" (454.6 mm)	26-1/4" (666.75 mm)	1-7/8" (47.6 mm)	8-15/16" (227.3 mm)	666270-XXX-C	Rp 2 (2 - 11 BSP, parallel)
6662X2-XXX-C	17-15/16" (455.1 mm)	26-3/8" (669 mm)	2" (50.8 mm)	8-31/32" (227.6 mm)		
6662XA-XXX-C	17-15/16" (455.1 mm)	26-3/8" (669 mm)	2" (50.8 mm)	8-31/32" (227.6 mm)		
6662XB-XXX-C	17-29/32" (454.6 mm)	26-1/4" (666.75 mm)	1-7/8" (47.6 mm)	8-15/16" (227.3 mm)		
6662XC-XXX-C	17-15/16" (455.1 mm)	26-3/8" (669 mm)	2" (50.8 mm)	8-31/32" (227.6 mm)		